



Hydro Systems Grow Guide

October 465

HIGH TIMES

POT JOBS

Start Your Cannabis Career Now!

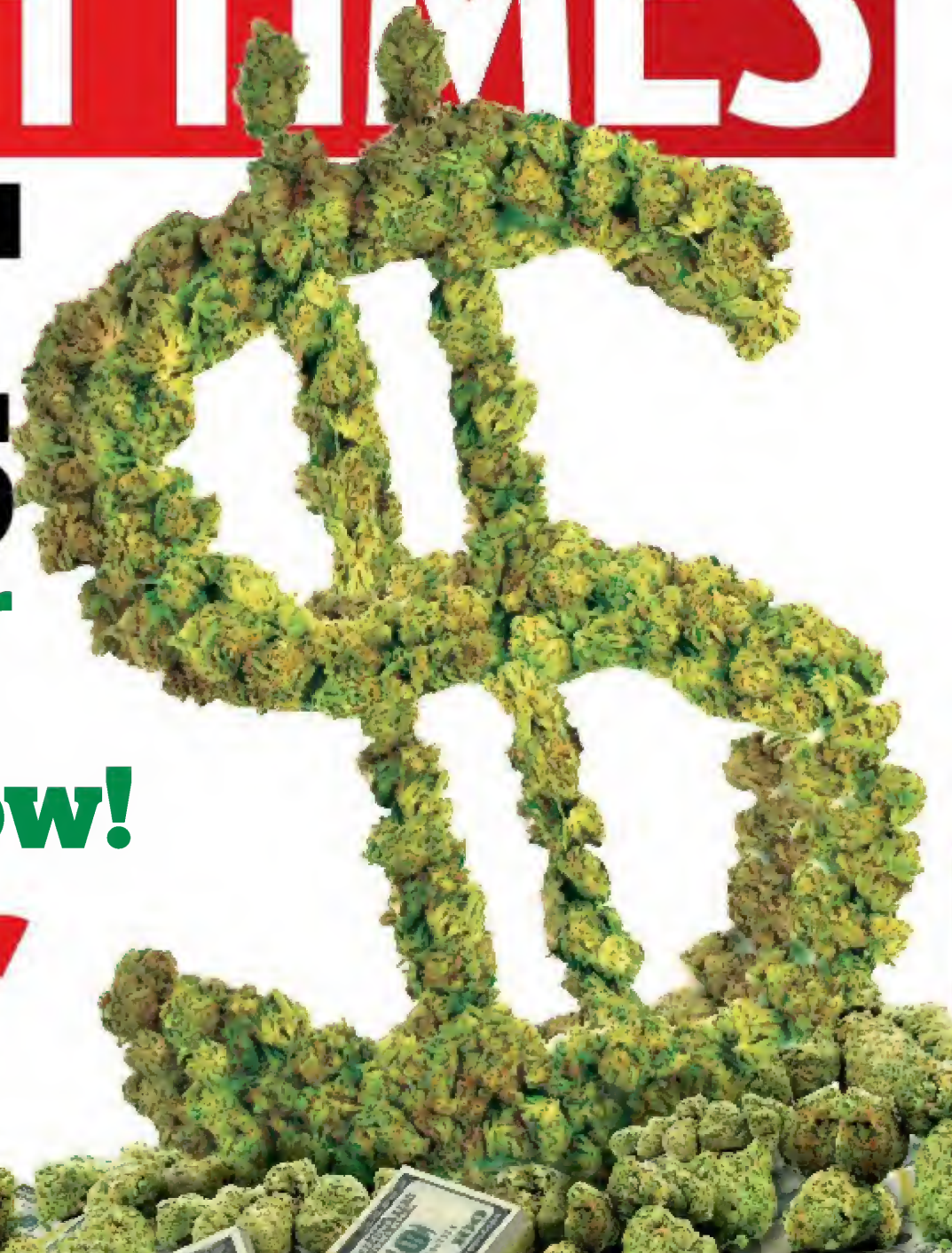

Behind the Scenes

The Ultimate Dab Lab

Cops Gone Wild

Alexander Shulgin's Last Trip

Godfather of Glass



HIGHTIMES.COM

October 2014 USA \$5.99 / FOR \$5.99



*In every strand
OF OUR
genetic code,
there lies an
ancient power.*

The power to heal.

BCBUD Depot

~ MEDICAL MARIJUANA SPECIALISTS ~

WWW.BCBUDDEPOT.COM

ACQUISITION OF LIVE CANNABIS SEEDS IS ILLEGAL IN THE UNITED STATES | PAYABLE IN US DOLLARS FROM ANYWHERE IN THE WORLD.



YouTube



BCBD

1-888-40-BCBUD

*Celebrating ten years of
worldwide shipping!*



*Fast, discreet
shipping
guaranteed!*

BC BUD DEPOT

WWW.BCBUDEPOT.COM



SOLD IN THESE DISPENSARIES:

- * JACKSON COMPASSION CLUB, JACKSON, MICHIGAN
- * PURE ALTITUDE - DETROIT, MICHIGAN
- * OREGON MICROGROWERY GUILD - EUGENE, OREGON
- * THE HONEY SPOT - LOS ANGELES, CALIFORNIA
- * 7 STARS HOLISTIC HEALING CENTER - RICHMOND, CALIFORNIA
- * THE HERBAL CURE - CRANSTON, RHODE ISLAND

WHOLESALE INQUIRIES:

EMAIL: WHOLESALE@BCBUDDEPOT.COM

UK WHOLESALE INQUIRIES:

BASIL BUSH LIMITED

BC BUD DEPOT SEEDS ALSO AVAILABLE AT:

- * THE ATTITUDE SEEDBANK - UK
- * GTA SEEDBANK - TORONTO, CANADA
- * THE LEMONADE STAND - KAMLOOPS, CANADA
- * SINGLE SEED CENTER - UK AND CANADA
- * ALIBONGO SHOP - UK
- * HERBIE'S HEAD SHOP - UK
- * KINGSTON HYDROPONICS - KINGSTON, CANADA
- * SEED CITY - UK
- * SENSIBLE SEEDS - UK

INTRODUCING CBD GOD

UP TO 16% CBD

ACQUISITION OF LIVE CANNABIS SEEDS IS ILLEGAL IN THE UNITED STATES | PAYABLE IN US DOLLARS FROM ANYWHERE IN THE WORLD.

SEED LIST

PRICES PER 12-SEED PACK

INDOOR / OUTDOOR

- BC GOD BUD - \$90 (())(())
- THE PURPS - \$90 (())(())
- GIRL SCOUT COOKIES Bx1 - \$90 (())(())
- SWEET GOD - \$75 (())(())
- CHEM FIRE - \$75 (())(())
- THE BLACK - \$75 (())(())
- BC MANGO - \$75 (())(())
- BC BLUEBERRY - \$75 (())(())
- THE BIG - \$75 (())(())
- SHIATSU KUSH - \$75 (())(())
- SWEET ISLAND SKUNK - \$75 (())(())
- ANIMAL COOKIES - \$90 (())(())
- BC SWEET TOOTH - \$75 (())(())
- BC CHEESE - \$75 (())(())
- 707 HEADBAND - \$75 (())(())
- BC HASH PLANT - \$75 (())(())
- BC NORTHERN LIGHTS - \$75 (())(())
- ULTIMATE PURPLE - \$75 (())(())
- BC KUSH - \$60 (())(())
- PURPLE BUDDHA - \$60 (())(())
- SOCAL MASTER KUSH - \$75 (())(())
- WHITE WIDOW - \$75 (())(())
- AMNESIA HAZE - \$75 (())(())
- FIRE OG Bx3 - \$75 (())(())
- ALBINO RHINO - \$60 (())(())
- BC BIG BUD - \$60 (())(())
- INDOOR MIX - \$50 (())(())

NEW CBD STRAINS

- CBD GOD - \$125 (())(())
- HARLEQUIN Bx4 - \$125 (())(())

OUTDOOR

- TEXADA TIMEWARP - \$75 (())(())
- BC PINEWARP - \$75 (())(())
- OUTDOOR MIX - \$50 (())(())

FEMINIZED

- BC GOD BUD - \$150 (())(()) ♀
- THE PURPS - \$150 (())(()) ♀
- GIRL SCOUT COOKIES - \$150 (())(()) ♀
- ORIGINAL BLUEBERRY - \$150 (())(()) ♀
- BC HASH PLANT - \$125 (())(()) ♀
- JACK HERER - \$125 (())(()) ♀
- SKUNK #1 X NL - \$125 (())(()) ♀
- SWEET DREAMS - \$125 (())(()) ♀
- CINDERELLA 99 - \$125 (())(()) ♀
- STRAWBERRY COUGH - \$125 (())(()) ♀

AUTO FLOWERING

- LOWRYDER #2 - \$90 (())(()) ♀
- BIGOMATIC - \$75 (())(()) ♀

Ⓜ = AWARD ♀ = 100% FEMALE

**ORDER SECURELY ONLINE,
BY PHONE OR BY MAIL**

*FREE SEEDS TO ALL CASH OR BLANK MONEY ORDERS!



GFS INDUSTRIES
108-800 KELLY ROAD, SUITE #471
VICTORIA, BC
CANADA V9B 6J9

AI VACUUM OVENS

- WINNERS' CHOICE -



1.9 Cu Ft 16x14x14"
Ambient to 500°F Vacuum Ovens
with High Speed Pump and Mist Filter

AI's award winning vacuum ovens are the No.1 choice for cup champions*. They are your BEST choice for curing and converting botanical extracts. With our new controller for precise low temperature operations, and deep vacuum level down to 100 micron, they can operate at temperatures which allow evaporation and degassing/purging to occur rapidly. This increases productivity and ensures the production of superior quality products with minimal processing time.

* Check our Instagram posts for a list of winners



Picture of botanical extract
provided by our client
Trichome Technologies



Mobile cart



Aluminum & st. st. shelves



LED lights kit

Vacuum Oven accessories



7.5 Cu Ft
22x24x25" Ambient to 500°F Vacuum Ovens

Visit us at:



High Times Cannabis Cup



Champs Trade Shows



@AcrossIntl

Phone: 888-988-0899 Email: info@AcrossInternational.com
Web: www.AcrossInternational.com



ACROSS INTERNATIONAL
Material processing equipment

NEW ELITE SERIES VACUUM OVENS

- PURGED TO PERFECTION -

Our newly released ELITE series vacuum ovens feature a new industrial leading 5-side jacket heating system that gives you perfect temperature uniformity, accuracy and fast heating rates.

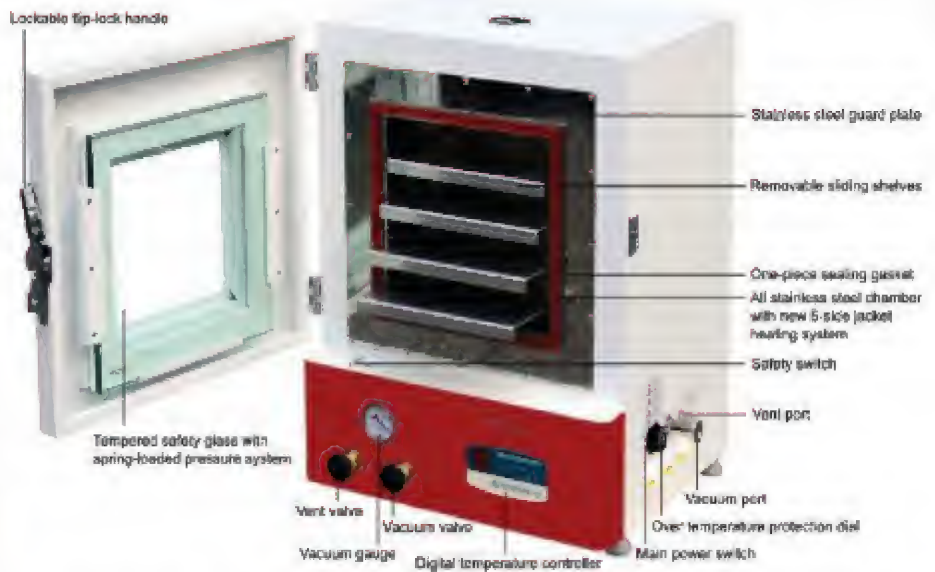

1 Cu Ft 12x12x12"
Ambient to 480°F Vacuum Ovens
with New 5-Side Jacket Heating System



Visit us at:



High Times Cannabis Cup



Champs Trade Shows



@AcrossIntl

Phone: 888-988-0899 Email: info@AcrossInternational.com
Web: www.AcrossInternational.com



ACROSS INTERNATIONAL
Material processing equipment

HIGH TIMES OCTOBER



"There are quite a few commercial hydroponic systems out there today, available in grow shops and online. Some of them come as turnkey solutions for indoor growrooms, while others are scalable and customizable depending on your needs."

—All Systems Grow, page 64

- 8 Internet**
- 10 Editor's Letter**
- 12 Letters**
- 14 Contact High**
- 21 Highwitness News**
Cops and canicide, the High Five and Global Drug War
- 31 Entertainment**
High Style, Mike Watt & Reviews
Food (p.38)
40-year Flashback (p.40)
Markets (p.42)
- 44 Gear**
- 109 Cultivation Clinic**
- 113 Dear Danko**
- 122 Ask Dr. Mitch**
- 124 The Dab Department**
- 126 Almost Infamous**
- 128 NORMLizer/FFOTM**
- 136 Pix of the Crop**
- 140 Next Month**
- 146 The Pot 40**

47 The Booming Business of Buds

Legalization and the cannabis industry's exponential growth means there's no shortage of opportunity to get your foot in the door. Check out our top pot jobs and get started—now! *By Jen Bernstein*

56 From Clones to Concentrates

TC Labs has built its brand by working closely with Colorado's top cultivators, processing the very best plants into high-powered concentrates. *High Times* checks out the company's new, state-of-the-art "dab lab." *By Dan Skye*

64 All Systems Grow

Nico Escondido provides a comprehensive list of indoor grow systems and mediums to help you decide what will work best for your space and plants, complete with advanced grow tips for both hydro and soil setups.

82 The Last Alchemist

Alexander "Sasha" Shulgin, perhaps the greatest psychedelic research chemist of all time, died on June 2, 2014. *High Times* spoke with Sasha and visited his alchemical hideaway a week before his death. *By James Kent*

91 The Fury in Missouri

Last March, a cannabis-friendly Facebook post set off an Internet firestorm between dog lovers and a disgraced former cop. *By Chris Simunek*

102 High Times Interview: Bob Snodgrass

Call him the "Godfather of Glass." Glassblowers speak in reverential tones of Bob Snodgrass, the artist who pioneered new techniques and a host of modern glassblowing tools. Now the man who launched the modern pipe movement speaks about his legacy. *By Jason Harris*

Be Legendary Baby

SASQUATCH GLASS

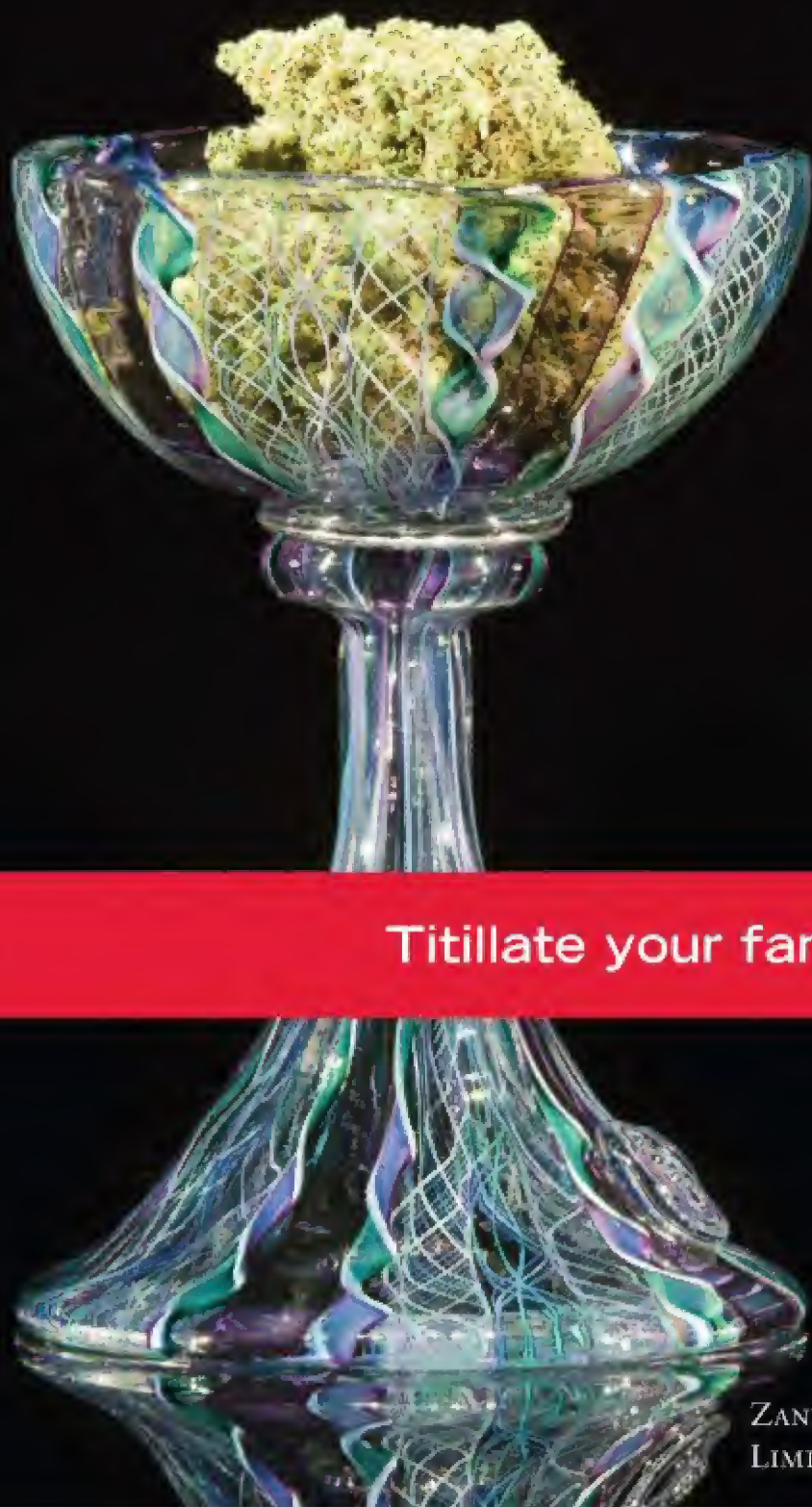

Titillate your fancy.

ZANIFIRICO TWISTED CANE UTILITY DISH
LIMITED EDITION COLLECTION

SASQUATCH GLASS

Our opulent Sasquatch Glass decorative artisan glass ware will arouse a strong response to your stylish legacy. Our glass is artful yet cultivated, significant but elegant. These statement pieces are spun by a three man glass blowing team. Each glass is individually handcrafted. It is our ambition to become legendary at our skill. We want you to have the best. Search and discover the Sasquatch Glass Artisan Collections.

Prove your legacy is one of style, uniqueness and quality. You will be remembered. You will - Be Legendary Baby.

SasquatchGlass.com



Seattle Washington



HIGH TIMES DIGITAL



Calling All Stoner Girls!

In response to your feedback, we've completely redesigned our Miss High Times website from the ground up—making it simpler, cleaner and easier to navigate, as well as adding new galleries and videos. We plan to add many more features in coming months, but for now we encourage everyone to log on to the beta site, create a profile and start posting! [Go to misshightimes.com](http://Go.to/misshightimes.com).

You Can Have It All!

We're thrilled to announce that the complete archive of *High Times* (that means every issue!) will be available online in October. Watch hightimes.com for the archive countdown!



Self-taught artist Matt McLamb heats up the glass scene.

Glass Artist of the Month

Based in the mountains of Vermont, Matt McLamb is a “studio rat,” working countless hours in his home studio. He’s a self-taught artist who’s been behind the torch since 2001.

Matt’s an innovator, constantly bringing new ideas to the table and experimenting with new techniques. He developed the technique of image transfer to glass in 2008, taking it from the soft glass industry and introducing it to the borosilicate world. His perfection of the technique has garnered lots of oohs and ahs, and his pieces are highly coveted.

Matt is also known for his kinetic glasswork, combining his two favorite interests—science and function. He’s known for making the first spinning pipe and many other kinetic creations. He placed second in the Pipe Classic VI with his 4-foot flying bird water pipe.

Like most American glass artists, his community has inspired him: “They push their personal limits and I try to push mine.”

POT POLL

The State of Your Stash

For most Americans, buying pot isn't like buying a quart of milk. Sometimes it's great, sometimes it's so-so and sometimes who knows? We asked a burning question: How's your stash right now? A third of the 2,200-plus respondents say they're smoking great weed. But a lot of you are dry. Sadly, nine said they're not sure what they're smoking. Our advice: don't!

Cast your vote in our latest poll online!

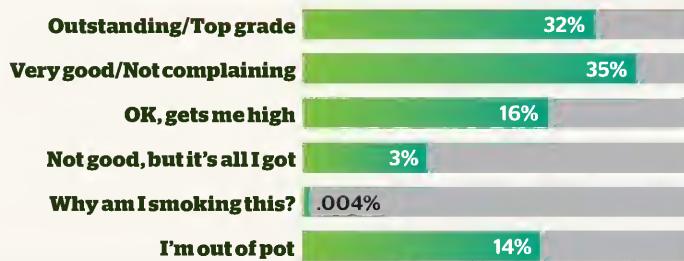

Miss October 2014

NAME: Faith
SCREEN NAME: Faith
CITY: Colorado Springs, CO
OCC: STUDENT
AGE: 30

To enter or rate contestants, go to misshightimes.com. You must be 18 or older to enter.

#rawlife

Wiz Khalifa



THE OFFICIAL
WIZ KHALIFA
ROLLING TRAY

Loud Pack
TRAY • RAW PAPER • TIPS

The Wiz Pack
RAW KINGSIZE SLIM + TIPS

Wiz Khalifa Tips

The Wiz Cone
RAW NATURAL UNREFINED CONE

THE OFFICIAL
WIZ KHALIFA
ROLLING TRAY



RAW
NATURAL UNREFINED ROLLING PAPERS

www.rawthentic.com

For wholesale inquiries please call HBI at 800-420-HERB www.hbiinternational.com

© 2014 HBI International, Inc. All rights reserved. HBI International, Inc. is a registered trademark of HBI International, Inc. www.rawthentic.com

Made in Alcoy Spain,
The birthplace of Rolling Paper

Cannabusiness 101

What a difference a few years make, eh? In the old days (not that long ago), when *High Times* was teaching people how to make a buck in the marijuana industry, it was by participating in an activity that, in their ignorance, the powers-that-be had declared illegal. (If you are like me, and happen to live in one of the less-enlight-

ened states in the nation, it's still illegal—but we're working on that). But now, the legal cannabis industry has grown at such an accelerated rate that there are literally thousands of employment opportunities open in dozens of categories, all of them aboveground, sanctioned

by state governments, and begrudgingly tolerated by the feds. We're talking about careers—professional positions that pay city, state and federal taxes, and in many cases include benefits. We're living in a new world, and *High Times* considers it our responsibility to help cannabis lovers out there get a foot in the door of this rapidly expanding legal cannabis market. That is the point of Jen Bernstein's article, "The Booming Business of Buds" on page 47.

Don't worry, we're still going to tell you how to grow marijuana while simultaneously avoiding the long and toxic arm of the law, and to that end, Nico Escondido's "All Systems Grow" on page 64 provides us with a breakdown of hydroponic systems where you can grow legal or illegal bud, depending on your circumstances. (In either case, we suggest you don't tell your neighbors about it.) For the dab fans out there, we also present "Clones to Concentrates" by Dan Skye on page 56.

And while we're talking about toxic law enforcement, we have two articles this month that detail the unsavory practices of cops and their bizarre relationships to the canine world, Russ Bellville's "Cops and Canicide" on page 21 and my own "Fury in Missouri" on page 91.

Finally, we pay tribute in this issue to a pioneer of psychedelic research. Alexander "Sasha" Shulgin, from a small cottage in Northern California, singlehandedly transformed the way we trip. James Kent, a psychedelic researcher in his own right, might have been the last journalist to visit him before he passed. Check out his touching memorial, "The Last Alchemist," on page 82.

Peace,

Chris Simunek
Editor-In-Chief



Legal cannabis at work.

HIGH TIMES

EDITOR-IN-CHIEF
Chris Simunek

MANAGING EDITOR
Jen Bernstein

ART DIRECTOR
Frank Max

SENIOR CULTIVATION EDITOR
Danny Danko

SENIOR EDITOR
Bobby Black

CULTIVATION EDITOR
AT LARGE
Nico Escondido

ENTERTAINMENT EDITOR
Polly Watson

LIFESTYLE EDITOR
Mary Jane Gibson

COPY EDITOR
Rick Szykowny

EVENT DESIGNER
Elise McDonough

ASSISTANT ART DIRECTOR
Roxanna Allen

CANNABIS POLICY DIRECTOR
Jon Gettman

LICENSING AND PRODUCT
MANAGER
Sarah Muhlrud

CONTRIBUTORS
Paul Armentano,
Bianca Barnhill,
David Bienenstock,
Carrie Doorhy, Mel Frank,
Freebie, Andre Grossmann,
Brian Jahn, K of Trichome
Technologies, Kris Krane,
Lochfoot, Mark Miller,
MzJill, Samantha Nicholas,
Michael Simmons, Allen
St. Pierre, Subcool

RESEARCH ADVISOR
Dr. Mitch Earleywine

FOUNDING PUBLISHER/EDITOR
Thomas King Forçade
1945-1978

TO SELL HIGH TIMES, CALL:
(800) 998-0739

EMAIL: sellht@hightimes.com

EDITORIAL DIRECTOR
Dan Skye

DIRECTOR OF
DIGITAL MEDIA
Kelly Barbieri

WEB EDITOR
Mike Gianakos

DIRECTOR OF TECHNOLOGY
Craig Coffey

VIDEO/ANIMATION EDITOR
Tristan Fuge

SOCIAL MEDIA COORDINATOR
Eric Sandler

PUBLISHER
Mary C. McEvoy

ASSOCIATE PUBLISHER
Richard Cusick

DIRECTOR OF ADVERTISING
AND SPONSORSHIPS
Matt Stang

ADVERTISING REPRESENTATIVE
John McCooe

ADVERTISING MANAGER
Ann Marie Dennis

ASSISTANT TO THE
ADVERTISING DIRECTOR
Noore Yazigi

LIAISON HIGH TIMES
GROWTH FUND
Michael Safir

COMPTROLLER
Jose A. Gallego

DIRECTOR OF SOUTHWEST
PROMOTIONS
Cathy Baker

NATIONAL ADVERTISING OFFICE
250 West 57th Street
Suite 920
New York, NY 10107

TO ADVERTISE IN
HIGH TIMES, CALL:
(212) 387-0500

FOR SUBSCRIPTIONS
OUTSIDE THE US, CALL:
(386) 597-4316

FOR SUBSCRIPTIONS
IN THE US, CALL:
(800) 827-0228

TRANS HIGH CORPORATION

HIGH TIMES, October 2014 No. 465 (ISSN #0362-630X), published monthly by Trans-High Corporation, 250 West 57th Street, Suite 920, New York, NY 10107 • HIGH TIMES and Trans-High Corporation do not recommend, approve or endorse the products and/or services offered by companies advertising in the magazine or website. Nordo HIGH TIMES and Trans-High Corporation evaluate the advertiser's claims in any way. You should use your own judgment and evaluate products and services carefully before deciding to purchase. • Mail subscriptions (payable in US funds) and changes of address (please include most recent mailing label) to PO Box 422560 Palm Coast, FL 32142-2560 • Offices at 250 West 57th Street, New York, NY 10107 • Periodical postage paid at New York, NY, and at additional mailing offices • Manuscripts must be accompanied by a self-addressed stamped envelope • All contributions will be carefully considered, but the publishers and editors assume no responsibility for loss or injury to unsolicited material • Copyright © 2013 by Trans-High Corporation. Nothing in this publication may be reproduced in any manner, either in whole or in part, without specific written permission of the publisher. All rights reserved. "HIGH TIMES," "CANNABIS CUP," "MEDICAL CANNABIS CUP," "MISS HIGH TIMES," "PIX OF THE CROP," "POTCAST" and "BONGHITTERS" are trademarks and registered trademarks of Trans-High Corporation. All advertising and advertised products void where prohibited. POSTMASTER: Please send address changes to HIGH TIMES, PO Box 422560 Palm Coast, FL 32142-2560

PRINTED IN THE USA

PROUD SPONSOR &
OFFICIAL NUTRIENT OF

EST. 1991

HEMPFEST

SEATTLE

DUTCH
MASTER

NUTRIENTS

INNOVATION
SINCE

1998

*Coming
Soon*

We Listened, We Developed, We Mastered

COMMERCIAL EDITION

MEDIUM SPECIFIC • WATER CULTURE SPECIFIC • COIR SPECIFIC • SOIL SPECIFIC

The first range of nutrients designed specifically for commercial cultivators!
A unique nutrient for each popular grow method, indoor and outdoor!

www.DutchMasterNutrients.com

The Negatives of Testing Positive

I'm a board-certified physician's assistant (a.k.a. midlevel provider) who was recently terminated by a large medical group in New Mexico, despite having a medical cannabis card! I have filed a lawsuit for illegal termination and have done a couple of interviews, most recently with KOB Channel 4 here in Albuquerque, NM.

In a nutshell, I'm a disabled vet. I served in the US Air Force for six years and use cannabis for my PTSD. I am enrolled in the New Mexico medical cannabis program, but the Presbyterian Medical Group has terminated me for "failing a drug screen." The only substance found in my blood was THC—but despite providing them with a copy of my medical cannabis card and ID, I was still terminated. I am not only a medical provider but a patient as well. So I'm suing the Presbyterian Medical Group for illegal/discriminatory termination, and I was wondering if your readers and my fellow medical cannabis users would support me in this fight!

Thanks for all the good work!

D. Smith

Where's the Real Kind Bud?

The market's bottom line is always primarily driven by volume and margins, not quality. Invariably, there's never enough high-end bud available relative to demand anyway—and a largely unknown but well-established micro-market of high-end connoisseurs tends to grab the lion's share of anything really good at a higher price before it disappears into a now more accepting and growing public marketplace.

I've seen it far too much in the Pacific Northwest: dispensaries that purportedly have something "top shelf," though the quality, more often than not, falls into the category of upper-level commercial (at best) in my pot veteran's catalog. It's often dry and crumbly, and many times the strains look like they came from the same source or seem too similar to one another. As Laurence Cherniak pointed out in his *Great Books of Hashish*, popularity and high business volume always affect quality negatively. As with most dealers, dispensary owners don't really want the super bud on their shelves: They make far more off the margins from upper-level mids passed on to unsuspecting and naive newbs as top-shelf dank ... you dig?

SR



Marijuana has been a medicine to help us vets maintain our sanity with the normal world we once protected.

Vets Need Cannabis Now!

My name is Crystal Hall. I am an army veteran. I joined the army at the age of 19 after high school. My first duty station was South Korea. Alone away from home I got raped by two military personnel. I continued to my service and deployed two years to Iraq. I was a single mother of a six-month-old and had to leave home to fight for her freedom. I have MST (military sexual trauma), PTSD, severe anxiety and depression. I served my country proudly but I'm writing about the vets and marijuana as their medicine. I have been nothing but a guinea pig for pills. I found that a nice joint would do just the same. People really don't realize when we served we gave our freedom and our well-being up for them to enjoy life and go on living life the way they know. People don't look at us the way we deserve to be looked at or treated. Since I completed my time and treat myself with pot, I have been criticized. The state takes my kids, people say I'm nothing but a lowlife, and I'm treated like garbage because I smoke marijuana. I don't understand how or why the government, or people that have never served, can judge us. I've seen things a normal person has not seen. It is instilled in our heads, all the violence and hatred

Send your letters to
Feedback c/o
High Times, 250 West
57th St., Suite 920,
New York, NY 10107
Email: hteditor@hightimes.com

we veterans have seen. When we come home how can we deal with that on a daily basis? Myself and many vets have turned to marijuana to help ease the painful memories that we endure. Please help us. We went and died to protect everybody at home. Marijuana has been a medicine to help us vets maintain our sanity with the normal world we once protected. Don't forget about us. Help us legalize marijuana for vets.

Crystal

Forced to be an Outlaw

I am a disabled veteran. I suffer from schizoaffective disorder bipolar type. And I have arthritis. Among my many symptoms are anxiety, depression, muscular joint pain and inflammation. Sometimes I am beset by thoughts of suicide, anger at my condition, and a sense of hopelessness.

Even with my regular brain meds, there are times when my symptoms overwhelm me. At those times cannabis is the medicine that brings me back to a place of safety and comfort. The medicine is strain-specific, so to ensure a supply of the correct strain, I grow my own. However, under New Hampshire's law I don't qualify for medical cannabis. And even if I did, I wouldn't be allowed to grow my own. So, because I choose to reduce my suffering and discomfort as much as possible, I am an outlaw, risking jail for peace of mind.

On a lighter note: Did I miss something? It's been a while since I last read *High Times*, and now I'm seeing a new kind of concentrate or extract—or just what the heck is "wax"? I finally got the honey oil thing all figured out, and you spring this "wax" on me. What is it and where does it come from? Is there a back issue that covers this? I have to ask, not because I'm stupid, just old and in the way!

Uncle Lee, NH

Bobby Black responds: Wax is just a specific type of butane honey/hash oil with a soft, "waxy" consistency. For more in-depth info on concentrate terminology, go to hightimes.com/read/official-dab-dictionary.

A High Times Cannabis Cup Winner 2011 Amsterdam
and now...
Winner at Spannabis Barcelona 2014
1st Place Interior Hydro



Buddha Tahoe....



....A modern day classic.
Call the Feds...

www.bigbuddhaseeds.com



**Contact
High**

ALL SYSTEMS GROW Pot plants exhibit explosive growth rates when hydroponic systems are fully dialed in and heavy branches need trellising for support. Learn all about the many different styles of indoor hydro in Nico Escondido's article on page 64. Bonus: Nico's Cultivation Clinic on page 109 details efficient ways to use trellises to harvest more buds. *Photo by Lochfoot*







GET A JOB Marijuana lovers can now legally work in their field! One of the top jobs in the industry is the ever-important trimmer. It's a meticulous, demanding gig, but the payoff is high; these industrious trimmers are clearly enjoying their work. For an in-depth look at careers in cannabis, check out Jen Bernstein's "Booming Business of Buds" on page 47. *Photo by Dan Skye*

**Contact
High**

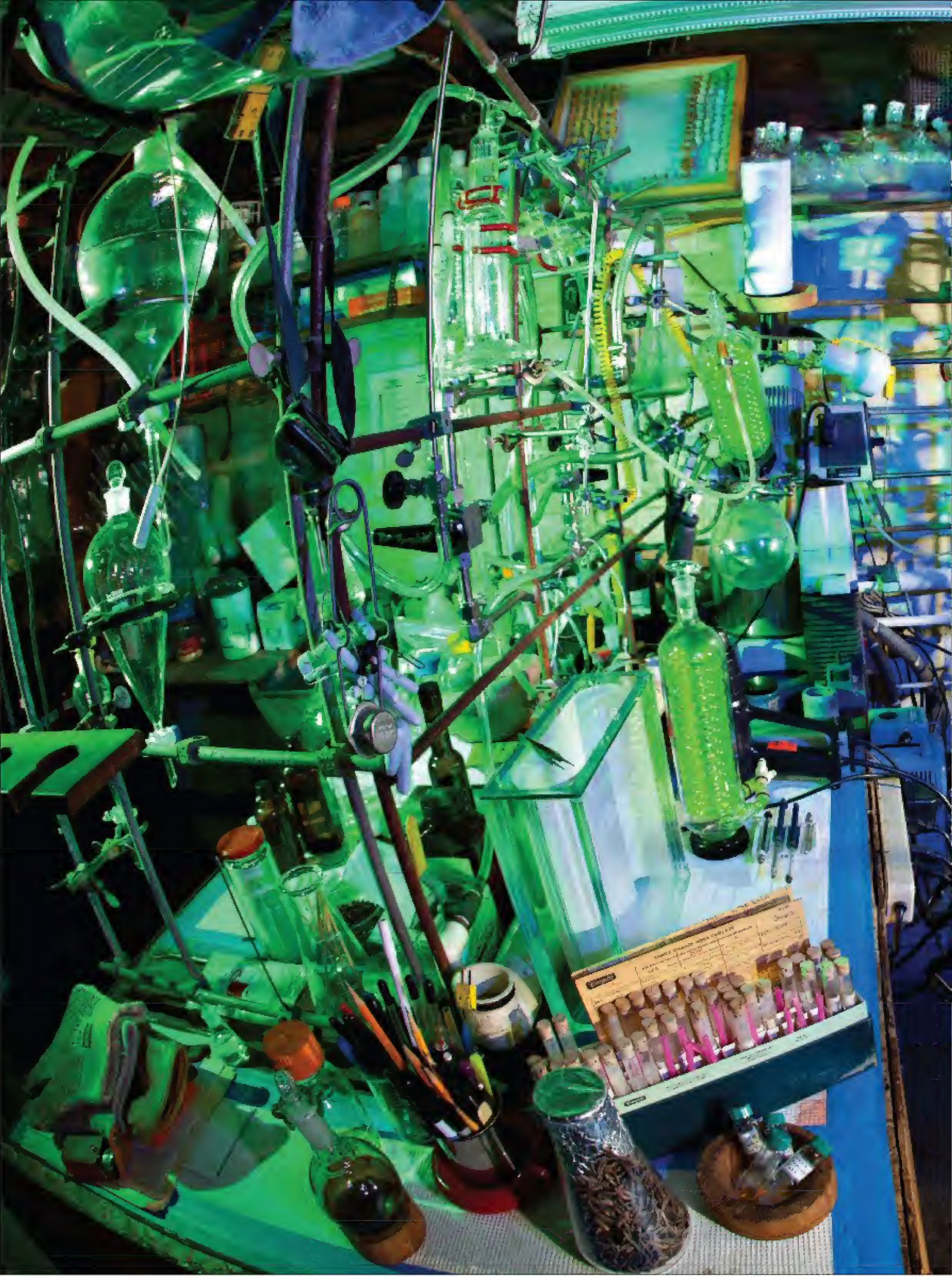



October 2014 *High Times*

THE ALCHEMIST'S HIDEAWAY In this lab, over the span of decades, Alexander Shulgin, "Sasha" to his friends, synthesized hundreds of psychedelic compounds. He also did groundbreaking work isolating terpenes and cannabinoids in cannabis. James Kent visited his headquarters in late May. A week later, on June 2, 2014, Shulgin passed on to the other side—his final trip. *Photo by Lochfoot*

19

**Contact
High**

OFTEN IMITATED **WILL NEVER** DUPLICATED

They say that that imitation is the ultimate form of flattery ... really???

The fact is, every new nutrient manufacturer (and even the old guard) want to compare themselves to our products. It would appear we are the hydroponics nutrients measuring stick.

Some say they magically "acquired" one of our secret formulations ... Others claim they "reverse engineered" their own copies of the same products we produce — only cheaper ...

These are the same formulations we (one of only three companies in the world granted a National Government license to grow cannabis) perfected over the course of eight generations of product improvements discovered during 15 years of cannabis specific research and development by a team of 23 plant PhD's—supported by a small army of undergraduates ...

... The same formulations we perfected using some of the world's most sophisticated plant tissue testing equipment like our quadrupole gas chromatograph in our state-of-the-art Bulgarian laboratory that measures to the parts per trillion ...

... Come on ... Really?

Look, you're smarter than that. We all know the imitation cola you buy from discount stores are "reverse engineered" to copy Coca-Cola® too. But is it exactly the same? Absolutely not!

Everyone knows, at the end of the day, there is only one "real thing".

Bottom line is ... can you or do you really want to risk your valuable cannabis crops and your hard-earned money on unproven claims sold on the basis of "cheap"?

Sincerely,

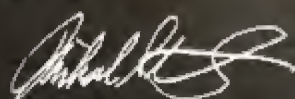

Michael "Big Mike" Straumietis

 **Advanced Nutrients**
Revolutionizing Plant Potential



Highwitness News

Light Up & Laugh with the Lucas Brothers!



Entertainment

High Wattage

Down the memory hole with Mike Watts. p.32

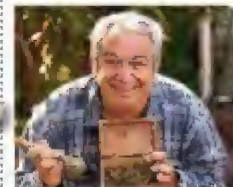

Food

Avocado Dragon Cake

Sticky green dragon sugar offers a super stone. p.38



Cops killing pets is another Drug War atrocity.



issue? Why haven't they heard this news from the American Society for the Prevention of Cruelty to Animals (ASPCA)? Shouldn't the Humane Society of the United States (HSUS) be addressing the media about this epidemic of animal killings by police?

That's right—*epidemic*. There are so many instances of canicide by cop that "Dogs Shot by Police," a Facebook page founded in 2012, has over 10,000 "likes." The site contains hundreds of local news stories about devastated families whose beloved pets were pointlessly executed by the police.

In one case in Louisiana this past

April, two young men were traveling from Maine by hopping freight trains. Accompanying them was a 14-month-old Newfoundland-Labrador golden retriever mix named Arzy. To escape the rain, the two men and the dog sought shelter in the back of an empty truck in a parking lot. Police arrived with guns drawn to investigate. The two men were polite and compliant and even tied Arzy's leash to a fence when ordered to do so by police. One of the cops cuffed the men and turned them away from the dog. According to an eyewitness working nearby, the cop bent down and petted the friendly Arzy. Then he backed up and shot the dog in the back of the head. According to the two men, the cop smiled at them and claimed Arzy bit him in the foot—something the eyewitness says never happened.

Cops and Canicide

The police are routinely murdering dogs in their marijuana raids. Where's the outcry? *By Russ Belville*

"Canicide by cop" is the phenomenon in which law-enforcement officers shoot and kill pet dogs in the performance of their duties. People may imagine the scenario of a late-night, no-knock raid in which a cop has to shoot a snarling pit bull charging to attack him—even though the cop is wearing bulletproof armor and there's never been a documented instance of a family dog killing a police officer. However, the reality is that cops are killing pets as a matter of routine procedure—and sometimes as a method for achieving the "shock and awe" intimidation of drug-raid victims.

Canicide by cop doesn't just take down pit bulls, Rottweilers and German shepherds; it also kills corgis, dachshunds and even Chihuahuas. And the death toll extends beyond man's best friend: In one Ohio incident, a "humane officer" responding to a call about a litter of feral kittens living in a woodpile shot them all to death in full view of a group of screaming children, while in a Staten Island bust—over a misplaced traffic cone, believe it or not—the cops even stomped a parakeet to death.

Where is People for the Ethical Treatment of Animals (PETA) on this

« Cases like Arzy's are not as common as the ones in which police serve a warrant in a marijuana investigation and then kill the dogs to teach "potheads" a cruel lesson. In Detroit, cops making a marijuana bust shot a man's pit bull, which was safely confined behind a locked fence. Then they entered the home to chase down and shoot two other dogs in the back, even as the owner begged the police to be allowed to put the dogs out of harm's way.

In another pot-raid-turned-dog-massacre, a Columbia, MO, police officer was heard explaining: "When you deal dope and the police have to come to your house, that's what happens."

But what about nonlethal options, like tasers and pepper spray? According to New Jersey State Patrol Capt. Stephen Jones, who was responding to an incident in which the state police shot and killed a woman's dog in an alley, tasers are "generally not too effective on a charging animal. Pepper spray is clearly not effective on most dogs."

Hmmm ... then why do postal workers, deliverymen and meter readers carry pepper spray?

I reached out to PETA for a response, but never heard back. I even wrote

The cops are trained to "neutralize the threat" of a dog during a search or arrest, and department protocols always back them up if they claim they felt threatened by the dog.

directly to one of their most prominent board members, animal lover and pot-smoking comedian Bill Maher, hoping he'd help focus attention on some of the most common legalized animal cruelty happening in America. I never heard back from him, either. Maybe if somebody were skinning dogs for fur coats, à la Cruella de Ville in *101 Dalmatians*, there'd be a reaction from PETA.

To their credit, the HSUS and ASPCA have at least tried to address the epidemic. According to an article on the *Huffington Post*, "Groups like the Humane Society and the American Society for the Prevention of Cruelty to Animals offer free training to police departments, but both organizations said few departments take them up on the offer."

It's a shame they don't, because it's the same kind of training that postal workers receive regularly on

understanding canine body language, establishing dominance and dealing with the few aggressive dogs out there.

Meanwhile, the cops in these stories are rarely disciplined and almost always keep their jobs. What happens is this: The police department conducts an internal investigation and routinely finds that the officer acted "according to procedure." The cops are trained to "neutralize the threat" of a dog during a search or arrest, and department protocols always back them up if they claim they felt threatened by the dog.

Psychologists often say that cruelty to animals is the first sign of a developing sociopath. So perhaps we shouldn't allow such cruelty to be a part of any police department's standard operating procedure. ✨

Listen to The Russ Belville Show at radicalruss.com.

HIGH FIVE

Marijuana Metropolises

Stoners abound in our nation's most populous regions. *By Mark Miller*

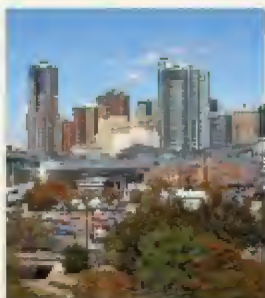

Colorado Front Range
Amsterdam is no longer the planet's marijuana mecca. Denver is! A recent *Movoto Blog* review calculated that there's one Mile High dispensary for every 3,780 residents—to say nothing of the recreational pot shops that have opened since then. Neighboring Colorado Springs and Aurora are also high on the list in terms of dispensaries per capita and headshops. And don't forget Boulder. It's been pot-friendly since long before it was legal!

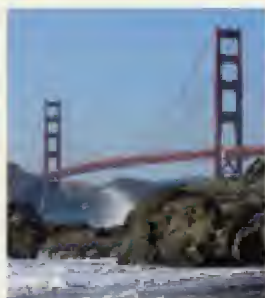

San Francisco Bay Area
Home to arguably the world's best weed, this region is where the medical marijuana revolution started in the 1980s, leading to Prop. 215's landmark approval in 1996. San Fran voters also passed Proposition W, designating pot as the lowest law-enforcement priority, way back in 1978. Across the bay, Oakland makes the top 10 for dispensaries per capita. Nearby San Jose ranks fifth for medical pot shops.



Seattle Metro Area
The Seattle Hempfest is a three-day pot rally unlike any other. Though Washington State lags behind Colorado in establishing retail recreational weed, Seattle still boasts the fourth-most dispensaries per capita in the nation. Even before Initiative 502 passed in 2012, Seattle Mayor Mike McGinn supported legalization, and in 2010 City Attorney Pete Holmes announced simple possession would no longer be prosecuted.



Greater Los Angeles Area/the Southland
Due to its massive population, LA ranks ninth in dispensaries per capita, but it still has the most in the nation—at least 450—despite a voter measure intended to limit their number to 135. The City of Angels also has the most medical marijuana patients (over 56,000 and climbing). Meanwhile, San Bernardino has the most headshops per capita among the 100 most populous cities in the US.

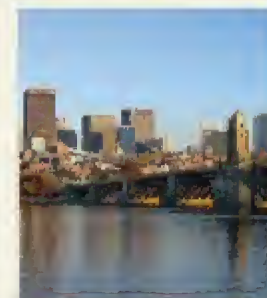

Greater Boston
Massachusetts may be the East Coast's answer to Colorado and California in terms of quality. Since 2009, personal possession in the state carries only a \$100 fine and no criminal record. The first medical marijuana dispensaries are set to open in Beantown this summer. With nearly 30 colleges, the pot scene is thriving. Plus the annual Boston Freedom Rally is the second-largest cannabis convocation in the nation.

Get Over 5 Harvests Every Year In A Fully Automated Growing Appliance

Start Today And Have Your First Harvest In 10-12 Short Weeks



The Roomate

Big Grows In Small Spaces



The Bloombox

2 Chambers For Faster Cycles



The Producer

Flower 18 Potent Plants



Incredible Odour Control

Odour crushing carbon filters scrub the air and keep your grow a secret.



Bud Boosting CO₂ Dosing

Control pests and get bigger yields with built in CO₂ control.



Easy To Use Automated Timing

One central timer controls all parts of your grow, lighting, watering, CO₂.



Hardcore Medical Grade Finish

Made to last, our grow boxes are built strong with powder coated aluminum.



Professional & Safe Wiring

Every BCNL Grow Box is a safe, reliable growing appliance.



Award Winning Quality & Yields

With 8 HIGH TIMES Stash Awards and counting we build boxes you can trust.

Can you recognize the early warning signs of plant distress? Do you know how to fix them? Our team of grow consultants can, and when you team up with us you never have to worry about losing a valuable crop.

That's because we not only believe in building amazing grow boxes, but we also provide industry leading grow support. Support that makes sure that every harvest you pull from your grow box is an incredible one.

Our Grow Consultants Can Answer Your Questions:

1-888-236-1266

www.BCNORTHERNLIGHTS.com/hightimes



Connect at:
fb.com/bcnorthernlights

Grow Consulting Team:

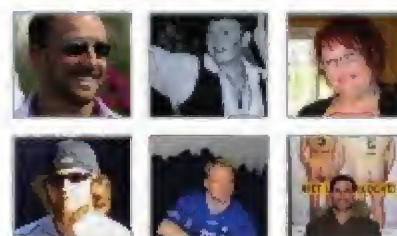



Teens & Pot—Not!

Let's kill another myth: Legal pot doesn't lead to increased teen use. Despite medical marijuana's legality in nearly half of the US, pot use among high-school students is essentially unchanged, according to the latest Youth Risk Behavior Survey issued by the Centers for Disease Control. The students fill out the research questionnaires anonymously, self-reporting their own pot and other drug use.

Last year, 23.4 percent of teens reported getting high one or more times a month, compared to 23.1 percent in 2011. What's more, pot use is down by more than 3 percent from its peak in 1999, when 26.7 percent of the teens participating in the survey said they toked. Alcohol and tobacco use are also in decline, suggesting that pot legalization might actually reduce teen usage by eliminating the youth appeal of the "taboo factor."

No data are available yet for Colorado and Washington in 2013, the year both states legalized recreational pot. However, from 2009 to 2011, years in which medical marijuana was already legal in Colorado, teen cannabis consumption in the Rocky Mountain State decreased almost 3 percentage points, from 24.8 to 22 percent.



Harvesting Happiness

It's been said that a surgeon's duty is to tranquilize the temper, beget cheerfulness and impart confidence of recovery. Certainly, the same can be said for pot growers at harvest-time. Their crops will tranquilize the temper, beget cheerfulness, and impart confidence of recovery—no matter what the ailment!

Flyin' High

Legal cannabis can't take all the credit, but Denver International Airport had a record number of passengers in April—over 4 million, up 130,275 from the same time last year.

April, of course, is the month of 4/20. Along with the High Times Cannabis Cup in Denver and a citywide celebration culminating in a downtown rally that drew thousands of people, it's only natural that pot tourism would contribute to the spike in Colorado travel—especially since legal retail pot shops have been open since January.

The total number of passengers to Denver International Airport is up 2.1 percent from last year. Furthermore, international travel has risen 24 percent.

Butts & Buds

Remember the urban legend that Big Tobacco had plans in place to sell packs of joints like cigarettes? Guess what? That was no myth!

Newly uncovered archives at the University of California in San Francisco reveal that in the '60s and '70s, tobacco corporations *did* explore marketing weed. Published in the health-policy journal *Milbank Quarterly*, the documents include a 1969 letter from a Philip Morris VP asking the Federal Bureau of Narcotics (the forerunner of the DEA) for a clandestine sample of pot for the company to study. The FBN's drug sciences chief, Milton Joffe, replied that Philip Morris—the maker of Marlboro, Merit and other famous brands—could bypass a standard application review by the Food and Drug Administration for obtaining the ganja. (No

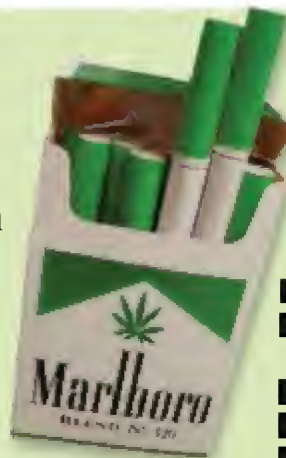

documents exist to indicate that the research actually took place.)

Additionally, an unsigned note explained Philip Morris's interest in packaging pot: "We are in the business of relaxing people who are tense and providing a pickup for people who are tired or depressed. The only real threat to our business is that society will find other means of satisfying those needs."

In 1970, British American Tobacco (Kent, Kool, Lucky Strike) conducted covert research in the U.S., dubbed the "Pot Project." Chief science advisor Charles Ellis proposed a plan for BAT to sell "cannabis-loaded cigarettes" in the form of tobacco cigs supplemented with "dried and cut cannabis rag" (i.e., ground-up pot).

In 1992, executives with R.J. Reynolds (Camel, Salem, Pall Mall)—motivated by false rumors that a French company was producing butts with buds—advocated analyzing pot "in view of the possibility of its future more frequent use in certain European countries."

Today, however, all of these tobacco companies deny any interest in marketing marijuana. That's one myth we won't buy.

“America’s Favorite Edible”

-High Times™ Magazine, April '14 Issue



175 MG
THC

35 Calories
per Chew

2 Cannabis
Cup Awards

The **DECA DOSE™** chocolate taffy Cheeba Chew™ is a Colorado and California Cannabis Cup award winner.



Propaganda Parade

Pot is addictive and harms its users' health. How do we know that? Because Dr. Nora Volkow, director of the National Institute on Drug Abuse, says so. In June, she was cited as the lead author of "Adverse Health Effects of Marijuana Use," published in the *New England Journal of Medicine*. The NIDA report maintains that pot is indeed addictive and that 9 percent of its users become hooked.

We're hardly surprised by NIDA's anti-pot bias; it's a federally funded research institute that echoes the US government's longstanding prohibitionist policies. But seriously now ... addiction?

The NIDA report also cites the problems associated with tobacco and booze as examples of why pot should remain criminalized, proclaiming: "We don't need a third legal drug."

Third? Legal prescription drugs don't qualify? They often cause serious side effects—including the possibility of fatal overdose, something that can never happen with pot.

Finally, Volkow reinforces her total lack of credibility when she calls pot a "gateway drug." As far back as 1999, the Institute of Medicine of the National Academy of Sciences wrote: "There is no conclusive evidence that the drug effects of marijuana are causally linked to the subsequent abuse of other illicit drugs."

Jamaica Wrestles with Legal Ganja

This fall, Jamaica's parliament is expected to vote on a proposal to allow possession of up to two ounces. Small amounts would still be "ticketable" offenses, but medical or religious use would be decriminalized. Confusing? Absolutely. A *Jamaican Observer* editorial questioned the logic of the new law: "How does fining people square with the government's proposal to allow the use of the herb for religious purposes?"



Reefer Racism

Despite an election-year pledge by New York City Mayor Bill de Blasio, the Big Apple's racist war on marijuana users continues undisturbed. After a decline in the number of petty pot arrests in the harsh winter months of January and February 2014, low-level weed busts increased in March and April compared to the same months in 2013—mostly in low-income minority neighborhoods.

According to the latest report from the Marijuana Arrest Research Project, during the first four months of 2014, the NYPD made an average of 80 minor pot arrests per day, which puts the city on pace to equal the 28,000-plus people popped for petty possession in 2013 under former Mayor

Michael Bloomberg.

Breaking down the busts demographically further reveals the racial and class bias. Through April, poor minority neighborhoods were hammered: East New York had a total of 500 pot arrests, and Morris Heights in the Bronx saw 392. But the high-income neighborhoods on the Upper East Side and Upper West Side of Manhattan recorded only eight each.

Overall, 87 percent of those busted for weed across the city's five boroughs were either African-American or Latino. Sadly, 73 percent of the arrestees had no prior convictions, thereby permanently staining their records.

The Big Apple won't be surrendering the title of "cannabis arrest capital of the world" anytime soon.

Late White North

When the Canadian government ran the country's medical marijuana program, Health Canada's performance was abysmal—inferior cannabis products, backlogged patient applications and badly written cultivation laws. The agency completely revamped the program as of April 1, barring patients and caregivers from cultivation and allowing licensed cannabis companies to handle the action.

Unfortunately, the bureaucracy hasn't improved. Thus far, Health

Canada has approved only 13 licensed suppliers. The agency attributes the delay to the overwhelming number of applications (858 as of late May) and an extensive vetting process.

Supplier license applications continue to pour in at an average of 25 per week, putting Health Canada further behind the eight-ball. To ease the pain, a March injunction by a British Columbia judge allows previously registered patients and caregivers to continue ganja gardening until the agency gets its act together.

Relocation & Medication

"I'm trying to help Greg die with dignity and peace." That's the reason given by Deb Ploetz, 63, for moving from Texas to Colorado so that her husband can use medical cannabis to treat his serious mental illness.

Greg Ploetz played defensive tackle for the University of Texas Longhorns. An artist and art teacher, he now suffers from "mixed dementia" and frontal brain-lobe damage.

Greg's behavioral changes resulted in hostility toward treatment, including the medical professionals who assisted him and administered his five prescription drugs. After he was booted from his third Texas care-giving center, Deb couldn't bring herself to commit him to a state psychiatric hospital.

But she did recall giving Greg a joint earlier in the year, which visibly calmed him. She decided to relocate to Colorado, where cannabis is legal.

Every morning, Deb visits Greg in his assisted-living facility and feeds him a cookie containing a small drop of *indica* oil; each night she gives him a capsule of *indica* extract. These treatments calm Greg within 40 minutes and have enabled him to kick most of his prescription medications. He now allows the staff to shower him, and he's also able to finish his sentences.

"I'm not trying to get Greg high," Deb says. "I'm trying to give him peace of mind."

You have heard of the legend...now pay homage
to the great Chem Dog...

Wear the shirt whilst blazing
through the work of a true artist.



Elite Cannabis Enterprises
is pleased to bring you the
exclusive Chem Dog apparel line.



Glass: www.instagram.com/ChemDog_Glass
Apparel: www.elitecannabis.com

**CHEM
DOG**™

HIGHWIRE

Dispatches from the international drug war. *By Bill Weinberg*



Alfredo
Castillo

Ex-Vigilantes Register Weapons in Michoacán

On May 10, the Mexican government began to swear in members of Michoacán state's "community police" vigilante network as a new rural police force, part of an effort to bring the self-defense militias under state control. An initial 240 "community police" members gathered for the ceremony in the village of Tepacaltepec, a stronghold of the movement, where they received new blue uniforms and registered their rifles (or turned them in for state-issued AR-15s). The ceremony was overseen by the federal point man for Michoacán, Alfredo Castillo, who waxed florid for the occasion: "Those who, 15 months ago, said 'Enough!' and decided to confront those who did them harm—because of them, today we have the Rural Defense Force, which carries the same conviction of justice, of courage, valor and bravery needed to protect those whom we love the most: our families."

A former "community police" leader, Estanislao Beltrán, a.k.a. Papá Pitufo (Papa Smurf), was named as head of the Rural Defense Force. But José Manuel Mireles, the most visible leader of the movement, was not in attendance at the



Legaliza Perú!

Peruvian Pot Activists Target Right-Wing Paper

Members of the group Legaliza Perú staged a sit-in at the doors of Lima's conservative daily newspaper El Comercio on May 16 to protest an opinion piece by columnist Martha Meier that ran a week earlier. Meier's column carried the sneering headline *Y ahora ... el lobby de los pastrulos* ("And now ... the *pastrulo* lobby"). *Pastrulo* is Peruvian slang for someone who smokes cocaine paste—even though Meier was writing about the successful cannabis legalization march held in Peru's capital on May 3 (which makes this sort of like calling cannabis smokers "crackheads"). The column was full of the usual ridiculous claims that cannabis is "very addictive" and "affects mental health" (recycled from the world media's Drug War scare machine and duly accepted without question). Legaliza Perú's press release called Meier's column "inexact and prejudicial," which is being very polite.

The May 3 Global Marijuana March—known locally as the *Manifestación Mundial de la Marihuana*, or MMM—brought several hundred people to Lima's downtown Plaza Francia. The event has been growing in numbers every year since it was launched in 2010, which means that Peru's prohibitionist establishment has every reason to be worried.

ceremony—pointing to the likelihood that some vigilantes are refusing to register, even at risk of arrest or confrontation with the new "official" security forces.

Narco War on the Texas Border

Mexico's government has pledged to deploy more security forces to the state of Tamaulipas, where a little-reported full-scale war is being waged between rival narco gangs right on the Texas border.

Mexican Interior Minister Miguel Angel Osorio promised a "new phase" in the federal government's efforts after the May 5 assassination of Salvador Haro Muñoz, the Tamaulipas state

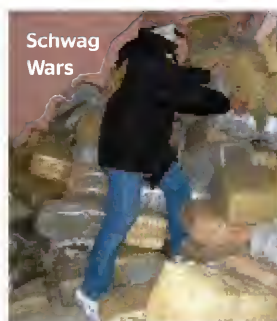

Schwag
Wars

intelligence chief, in an ambush on his car in the state capital, Ciudad Victoria. Ten officers from the Tamaulipas state police have been arrested by federal authorities in connection with the hit, which was said to have been carried out by the Zetas narco-paramilitary network. Also detained was José Manuel López Guijón, the security chief for Tamaulipas Governor Egidio Torre Cantú.

"We will strengthen

surveillance at ports, airports, customs and border crossings, as well as the major land routes," Osorio told a press conference in the border town of Reynosa. He said security forces will "patrol 24 hours, every day of the week, in main urban areas," and conduct reviews of local police forces to fight corruption. There's an ominous sense of *deja vu* to these developments, as the Mexican government has pledged many times before to get Tamaulipas under control with big troop deployments—only to escalate the level of violence each time.

Knights Templar Mineral Exports Seized
Mexican authorities on



Templars on the run!

May 1 announced the seizure of a ship carrying 68,000 tons of illegal iron ore bound for China, hailing it as the latest blow in a crackdown on the contraband-mineral sideline of the Knights Templar drug cartel. Federal police were apparently tipped off by an anonymous phone call after the ship left Lazaro Cárdenas, the Pacific port in conflicted Michoacán state. Authorities detained the ship, the *Jian Hua*, off Manzanillo, the next major port up the coast, in neighboring Colima state. Mexican authorities say they've seized over 200,000 tons of illegal iron ore so far this year, most of it headed for China.

Two days before the seizure was announced, Arquímedes Oseguera Solorio, the mayor of Lazaro Cárdenas, was arrested along with the city treasurer and other officials by Mexican federal police on suspicion of ties to the Knights Templar. Lazaro Cárdenas has emerged as the main export hub for the cartel, which is believed to be one of the main suppliers of methamphetamine to the United States. 🌿

For updates on these and other stories, see Bill Weinberg's websites, GlobalGarjaReport.com and WorldWar4Report.com.

LivWell

Enlightened **Medicine**

Check us out
on Weedmaps!

Follow us for specials,
event promotions, and
industry related news on
our social media pages.



Denver • Lakewood • Boulder • Colorado Springs • Garden City

***Recreational Wholesale Cannabis Available! Call (720) 360-6354**

Must have valid Recreational Business License to purchase wholesale.

Medical

Recreational

Rec Promo (21+)

\$99⁹⁹ Medical
Ounces

\$99⁹⁹ Recreational
Ounces

\$35⁰⁰ Medical
Quarters

\$40⁰⁰ Recreational
Quarters

\$20⁰⁰ Medical
Eighths

\$25⁰⁰ Recreational
Eighths

CANNABIS

Buy Any Gram of
Rec Cannabis
Get One Free

This Coupon Applies
to Any Shelf in
All Rec Stores

Offer Expires 09/10/14

Free gram promotion is subject to state purchasing limits and is valid only on recreational cannabis. Limit one free gram per person per day of equal or lesser value. Promo cannot be combined with any other discount or promotion. Free gram has a value of one cent and is subject to tax. Coupon, along with rec and med prices, subject to change or end without notice.

Recreational Locations (21+)

Store Locations

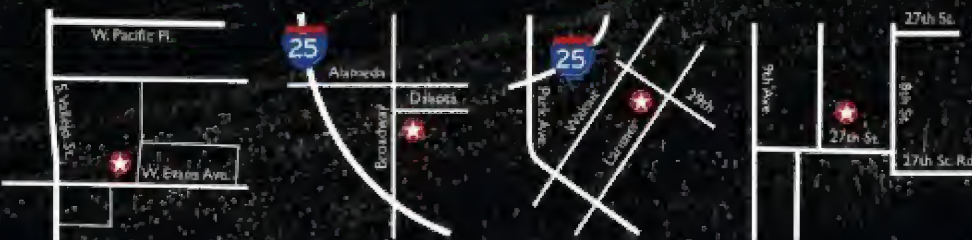

LivWell on Evans
Hours: 8AM-7PM
2193 W. Evans Ave.
Denver, CO
(720) 361-2981

LivWell on Broadway
Hours: 8AM-7PM
432 S. Broadway
Denver, CO
(720) 428-2550

LivWell on Larimer
Hours: 8AM-7PM
2863 Larimer St.
Denver, CO
(303) 484-1662

LivWell Garden City
Hours: 9AM-8PM
2647 8th Ave
Garden City, CO
(970) 616-6007

LivWell on Broadway
Hours: 8AM-7PM
432 S. Broadway
Denver, CO
(720) 428-2550

LivWell on Evans
Hours: 8AM-7PM
2193 W. Evans Ave.
Denver, CO
(720) 361-2981

LivWell Boulder
Hours: 10AM-7PM
3000 Folsom St.
Boulder, CO
(720) 389-4920

LivWell on Murray
Hours: 8AM-7PM
570 N. Murray
Colorado Springs, CO
(719) 574-8443

LivWell on Larimer
Hours: 8AM-7PM
2863 Larimer St.
Denver, CO
(303) 484-1662

LivWell Lakewood
Hours: 8AM-7PM
5660 W. Alameda Ave.
Lakewood, CO
(303) 922-9479

LivWell on Tejon
Hours: 8AM-7PM
1414 S. Tejon St.
Colorado Springs, CO
(719) 634-0420

LivWell on Nevada
Hours: 8AM-7PM
3234 N. Nevada Ave.
Colorado Springs, CO
(719) 622-6652

LivWell Garden City
Hours: 9AM-8PM
2647 8th Ave.
Garden City, CO
(970) 616-6007

*For information regarding promotions in Boulder, Colorado, please contact a store manager at that location.

Rec is available at LivWell on Broadway, LivWell on Larimer, LivWell Garden City, and LivWell on Evans.

For employment opportunities and updates please visit our website at www.livwellco.com



Hand Selected Seeds



WWW.DNAGENETICS.COM
SHOP ONLINE OR CALL US AT +31 207787220

ACQUISITION OF CANNABIS SEEDS IS ILLEGAL IN MOST STATES OF AMERICA | DNA GENETICS DOES NOT SHIP SEEDS TO THE U.S.A



Immerse Yourself

Adventuresome stoners will love the latest performance trend popping up all over the US: Immersive theater. The movement was pioneered by the wildly popular *Sleep No More*, set in a NYC warehouse transformed into an “abandoned” hotel. Audience members follow performers up stairs, down corridors and into gorgeously appointed rooms. It requires good balance and depth perception to keep up with the action, so being just a teensy bit toasted is ideal. Ditto for *Queen of the Night*, an over-the-top feast for the senses in an ancient ballroom under Times Square. The roast pig on a spit and boiled lobsters served to attendees as the performers cavort above and around the them would be perfectly complemented by a puff before the show.

This summer in Denver, Champa Street was transformed into an immersive arcade with body-controlled video games—made all the more enjoyable by legal pot. And this October, Seattle Immersive Theater presents *Supraliminal*, a site-specific show with a parapsychology lecture and a field investigation of “psychic phenomena.” Lucky Seattleites can take full advantage of legal marijuana to heighten their theatrical experience!



Keith and Kenny Lucas do everything alike.

Twin Hitters: The Lucas Brothers

For those of us who weren't born with a body double, the obvious question for the comedy team of Kenny and Keith Lucas is: “What's it like?”

Keith responds first (we think): “We go through identity crises all the time,” he says. “It's an existential breakdown. You have another you. It just trips me out sometimes.”

Kenny adds, “You sit in judgment all the time.”

Whatever the twin dynamic is really like, the red-hot Lucas Brothers have put it to good use creating absurdist, off-the-wall comedy. They're about to go on tour, while their new series *Friends of the People* has just debuted on TruTV. It's a cavalcade of scripted sketches and person-on-the-street segments. And *Lucas Bros. Moving Co.* is still chugging along, the animated series featuring the twins as cartoon characters who have inherited a moving van from their dead uncle. Plus the brothers passed their big-screen Hollywood test this summer, co-starring

as Channing Tatum and Jonah Hill's dorm mates in *22 Jump Street* and scoring some big laughs.

Asked whether their comedy has stoner appeal, Kenny responds, “I don't know what that means, man. I know most twin acts are kind of high-energy, but that's not us.”

“We're chill,” Keith adds. “We do what seems funny and go into some weird corners. Maybe stoners appreciate our comedy more because pot inspires it.” (For example, their inspired take on what it's like to 'shroom with someone who looks just like you.)

Or, as Kenny proclaims, “Individuality is overrated!” To amplify the point, Keith chimes in: “God bless the Olsen twins! We want that kind of money. They're showin' us how it's done!” *Dan Skye*

For tour date info and *Friends of the People* airtimes, visit thelucasbrothers.tumblr.com.

SPOTLIGHT

Cannabis Basics Naked Lip Butter

15 oz (4.25 g)

Naked Lip Butter isn't just a soothing salve that helps heal cold sores and chapped lips; it also keeps your kisser so smooth and supple that you won't be able to live without it. It's great for treating skin issues, too: Smooth it over your new ink to help that tattoo heal! Count Naked Lip Butter as a new necessity when you update your cosmetic routine. Its blend of cannabis and echinacea with restorative hempseed oil glides on like the smoothest hit you ever took, but it contains less than 0.3% THC, so you get lip therapy without getting lit. Available at several locations in Washington State. cannabisbasics.com



Watt's got pot!



“If I don’t write it out, it’s gone down the memory hole. But that’s why I like pot—it lets me let go of memory and relax.”

What do you think of pot legalization?

Finally, it’s happening. I was born in 1957 and grew up during the period where they blamed pot for *everything*. Like *Reefer Madness* in the 1930s—but they were doing that in the ’60s and ’70s, too.

Do you still miss D. Boon?

Without D. Boon, I wouldn’t have gotten into music. I celebrate his birthday [April 1], not the day he got killed. I dedicate a lot of my music to him.

High Wattage

When it comes to weed, Mike Watt knows when to hold ‘em and when to fold ‘em. *By Mark Miller*

Mike Watt’s majestic performances on bass and in the genre-defying music he produces are as fluid and flexible as his integrity is unyielding. Go ahead, just try and catch him doing anything “mersh” (Watt-speak for going commercial or selling out). He was a co-founder of the seminal 1980s group Minutemen, and after the tragic van-crash death of guitarist/singer D. Boon in 1985, Watt redefined himself with a dizzying array of creative projects, both solo and in bands. From his Southern Cali home in San Pedro, Watt spoke with *High Times* about everything from pot to what truly defines punk rock.*

You played on the Stooges’ 2013 album Ready to Die. What’s it like being a Stooge?

I was very honored to get to play on that. Without them, we wouldn’t have punk. I’ve now played [live] with the Stooges for 125 months. I would’ve never imagined it as a young man—they were such a big band for me.

Do you use pot?

I’ve smoked it since I was a boy. I use it before I go to sleep because it gets me calm and helps with my joints [laughs]. But if I try to use it while playing, I can’t remember anything ... can’t remember the chords or the lick I just did. And with alcohol, I can’t hear pitch

right. I play better straight. At an early Minutemen show, I played on L [LSD] because I didn’t know we had a gig, and I couldn’t hit the right chords. I’d have to practice playing buzzed [laughs again].

What about creating music while high?

Maybe some initial ideas, but I just can’t remember what I did. If I don’t write it out, it’s gone down the memory hole. But that’s why I like pot—it lets me let go of memory and relax.

Do you still practice bass technique?

Yeah, but I like to connect it to tunes—everything I do on bass is the foundation of serving the tune. The more notes you play, the smaller you get, so it’s about finding the right notes. The future of bass is composing, when you leave a lot of space for the other musicians on guitar and keys.

What defines punk music?

It’s not about a style of music, but a state of mind where you don’t feel you fit in, so you create a parallel world that makes more sense. ✨

**Thanks to bassist B. ILL of Sterile Jets for arranging the interview.*



Blazing On

Interviewed right before his 56th birthday, Watt said he’d play in two different bands that night. “Birthdays are like a lighthouse,” he says, “telling me how much work I still got to get done.” Thirty-five years after his first record, Mike Watt is still going strong.

THE  **ALS**

WHIZZINATOR

Touch!

The **FIRST** touch-and-go synthetic urine system by ALS.

MEDICAL GRADE SYNTHETIC URINE

LOOKS SO REAL
WE CAN'T SHOW
YOU THE REST!!!

SUPER
LIFE-LIKE
PROSTHETIC

GET OVERNIGHT SHIPPING!

THEWHIZZINATOR.com

(888) 895-7016



This product is not intended for any illegal purpose. Nor is it to be used to defeat lawfully administered drug tests.





Psychedelic or psychohellic?

“A toké here and there helps Oozing Wound keep the creative juices flowing.”

Inevitable destruction of our poor doomed planet Earth, the band purposely mix the vocals way down so that all lyrical nuance gets pretty damn lost.

“The best lyrics are the ones that you can’t understand, and that you find out are actually kind of interesting,” Weil explains.

“It’s that David Byrne thing where the vocals make you listen to a song longer than you would if they weren’t there,” Cribbin adds.

The post-post-nu-metallic “Call Your Guy” or the swagging, squawking aggression of “Spirit Manimal” contain what must surely be Riffs of the Year, among a major stack of other thrashing guitar lines that, upon close listening, send one into a trance state. This ultimate rifferini is near-scientifically worked out in order to, as Weil puts it, get “the most mileage out of the riff.”

“You gotta sit on it a while,” Cribbin says, “focus on it till it doesn’t even make sense anymore.”

A wee toké here and there helps Oozing Wound keep the creative juices flowing like a bubbling stream unto infinity. “It’s good for writing,” Cribbin avers. “It facilitates the experience.”

“When I write a lot of the riffs,” Weil says, “I’m aiming for creating this artificial zone, and pot is a really good aid in creating that kind of feeling.” ✨

Peel Your Face

Chicago noise-metallers Oozing Wound will leave you groping for your countenance ... and perhaps a bong. *By John Payne*

If it’s extreme metal we’re talking about, who needs melody, harmony or even “songs” when you can have a lotta heavy riffing and hatred and shouting? Take it from Oozing Wound, this is all that’s required. Their motto? “Get High, Fuck, Destroy.” It’s an attitude that bleeds all over their recent album *Retrash* (Thrill Jockey), a headbanging-to-the-50th-power experience that reduces the very concept of thrash metal down to its cathartic core.

There’s a zenlike purity to Oozing Wound’s approach: “We try not to think about it,” says guitarist Zack Weil. Then he laughs. So do his bandmates, Kevin Cribbin (bass) and Kyle Reynolds (drums). They snigger a lot, which might be because their whole trip is kinda funny,

when you think about it. The trio emerged from the wicked Chicago underground scene that spawned the ugly glories of noise/thrash/noise bands like Cacaw, Unmanned Ship, ZATH and Bad Drugs. For Oozing Wound, however, their chosen MO is a method that employs no method at all.

“We all listen to other kinds of music,” says Weil, “but the most fun stuff is the kind where you get to just *freak out* and see people freaking out. To those people, our stuff sounds like thrash or crossover or whatever, but there’s no real plan.”

“Not a conscious one,” Cribbin says. “But *we* agree with everything we’ve done.”

While song titles like “Everyone I Hate Should Be Killed” and “Autopsy Turvy” clue you in that Oozing

Wound are not some grim-faced dealers of Norwegian death metal, the songs’ insanely adrenalized rush makes it clear that these guys are *fast*. Indeed, they seem to draw on some kind of mystical inner mounting flame, or perhaps just huge loads of speed.

“No, we’re just working stiffs,” Cribbin says. “I’m not into ‘fast wars’—there’s always some faster cat on the block. But Zack is fast, Kyle’s a madman, so I gotta play fast too!”

Though the tracks on *Retrash* seem to address weighty issues like anger, paranoia and the



Vaped and Pillaged

Though Oozing Wound’s first cassette was titled *Vape and Pillage*, Weil prefers edibles and isn’t a huge fan of vaporizers: “They take part of the high away, and it’s not the same kind of fun. They make me clench my jaw a lot.”



CABINET GROW
WE MAKE GROWING EASY

GROW EASY

PLUG & PLAY GROW CABINETS



DISCRETE BILLING
AND SHIPPING



90 DAY MONEY
BACK GUARANTEE



MADE IN
CALIFORNIA



LIFETIME
GROW SUPPORT



2013 HIGH TIMES
STASH AWARD WINNER

YIELDER MAX

Built to last, the Yielder Max is the perfect starter system for first time, at home growers. It's completely stealth, easy to use, and comes ready to plug and grow.

- Available in Soil or Hydro
- Available with 200w CFL or LED (Flip 5w)
- Comes with everything you need to get started
- Just add seed and water
- Removable shelf for taller plants

*Shown with Hydro / LED setup



FLIP LED GROW LIGHTS

5w LED 2-in-1 light fixture

- Daisy chain the lights to scale for larger grow applications
- Simple to use. Just "flip" the switch to go from veg to bloom
- 110v/220v compatible, 700mA, 15 band light spectrum



ENJOY YOUR POWER TO CHOOSE.
PICK YOUR MEDIUM, LIGHTING AND SIZE.

VISIT US: CABINETGROW.COM
CALL US AT: 888-544-9376



Howling Hooks

The Queen City spawns a killer band.

Heavy reverie, indeed: This new album by the psychonautic Buffalo Killers is hard-hitting yet dreamy, filled with weighty guitar riffs matched by free-floating lyrics that loosely explore the head-space of brothers Zachary and Andrew Gabbard, the band's lead songwriters.

Heavy Reverie is Buffalo Killers' fifth studio album. The nearly decade-long journey from the band's 2006 inception has been blessed by a few milestones, including an extended tour with the Black Crowes, whose front man, Chris Robinson, called Buffalo Killers "one of the best fucking rock'n'roll bands in the world." Highly inspired, the band wrote half of their critically acclaimed *Let It Ride* album while on that tour.

My first impression of their latest was that the Rolling Stones and Black Rebel Motorcycle Club had a baby, one that was born howling and playing nothing but hooks. Yet as the album unfolds, the melodic tunes and catchy lyrics prove that Buffalo Killers have a rockin' sound all their own—one that keeps your head rhythmically bobbing and inspires you to keep the volume cranked. This is an album to jam to while you clean the house, navigate the hot curves of the highway or simply lie in the grass gazing at the sky. Smoke two joints and groove out hard.

The album opens with "Poisonberry Wine," a sweet and gritty song that wakes you up while allowing you to sleepily take in the morning hour. One of my personal favorites is "Cousin Todd," which is fun and engaging—just remember that Cousin Todd is a better junkie than you! "January" is the perfect song for when you're "in the back of your car ... smoking joints ... / Oh, the stars." The whole album flows thusly and is packed with great songs, making *Heavy Reverie* the perfect vehicle to elevate your mind while you're rocking your face off. *Mary Ought Six*



Buffalo Killers
Heavy Reverie
(Sun Pedal Recordings)

MUSIC RECOMMENDATIONS



The Skull Defekts
Dances in Dreams of the Known Unknown
(Thrill Jockey)

The third installment of this Swedish punkstuff's quest for cosmic clarification further transcends the noise/experimental underground that spawned it. Ex-Lungfish shaman Daniel Higgs intones oblique poetics while the brutally minimalist band sneaks in some aural insurgency via

the clanging motodrive of "Pattern of Thoughts" and the artcore riffsludge of "The Known Unknown." A riff-laden set that simmers with surreal electronic FX, *Dances in Dreams* is an enigmatic yet curiously tasty elixir that turns rock inside out to reveal its hidden wonders. *John Payne*

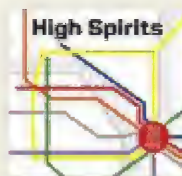

High Spirits
You Are Here
(High Roller)

In the studio, High Spirits is a man named Professor Black. Live onstage, High Spirits is a five-headed monster providing a real invitation to travel skyward. At the height of their powers, they're chuggin' like Priest, soarin' like Scorps, tuggin' on your heartstrings like Def Lep. On High

Spirits' sophomore studio effort, however, the professor falls short of the high-water mark left by his debut and the band's exhilarating live show. There are some golden moments here—especially the eponymous theme/anthem—but I'll be crankin' the demos 'til the van pulls back into town. *Pat Delaney*



Mount Carmel
Get Pure
(Alive Natural-sound)

I knew nothing about Mount Carmel before *Get Pure*, and despite the ubiquity of the Internet and its endless information, that's the way I want it. Offering another reason to pay attention, Alive Natural-sound Records is delivering tomorrow's classic rock today: Bringing their label

mates John the Conqueror to mind, Mount Carmel conjure a heavy, blues-centered and blastful amalgamation of Thin Lizzy, Blue Cheer and Lynyrd Skynyrd. *Get Pure* dares you to prove that the law of volume is something you will not only stretch to its scientific limits, but also far exceed. *Shawn Abnoxious*

BOOK RECOMMENDATIONS



DON1: The King From Queens
Louie "KR.ONE" Gasparro
(Schiffer)

Art refuses to be suppressed. With little training and zero gallery interest, the graffiti artists of the 1970s sprayed their visions across the New York City transit system and into the eyes of millions of captive commuters. Stalking the train yards of Queens, with a can of Rust-Oleum in one

hand and a spliff of Acapulco Gold in the other, DON1 became a master of the form while still in high school. Though his career was cut short by an accidental PCP overdose, his touching story is recounted here in a wonderful book by his contemporaries and protégés. *Chris Simunek*

GAME RECOMMENDATIONS

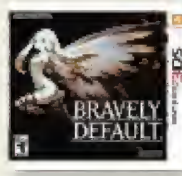

Bravely Default
Nintendo 3DS
(Square-Enix)

Square-Enix proves it is the reigning king of RPGs with the release of *Bravely Default*. Brilliant visuals and complex gameplay make this title a potential candidate for Game of the Year. The player will spend hours level-grinding both their characters and their specific job to come up with shockingly powerful

attacks, running through immensely detailed landscapes, and crawling in and out of bizarre dungeons. The plot is thought-provoking and often demented in the classic style of Japanese RPGs. A must-have for fans of the genre, or for the gamer who seeks a real challenge. *Mike Caiazzo*



#DimeBagTimes

Tag your Dime Bags photos
 #dimebagstimes @dimebagsstorage
 for the chance to be featured on our
 Instagram and in future issues of High Times

www.DimeBagsStorage.com
 www.Facebook.com/DimeBagsStorage

PRE-ORDER AVAILABLE!

Top Reasons Everyone Grows With SUPERCLOSET LED!

SuperCloset is the **ONLY** fully Automated LED Grow Cabinet that has the following:

SuperNova LED

78" h x 46" w x 24" d

Removable Rear Access Controls Controls on the back with beautiful "Stealth" look
"Odor Free" Guarantee Activated Carbon Air Filters

"Infra-Cool" Steel Cabinet
 16-18 Gauge Steel, Beautiful, Safe, Clean, Powder Coated Black

Adjustable Light Yo-Yo System
 Maximum Photosynthesis Penetration

Reflective Paneling
 Anti-Mold, Removable & Adjustable Panels

T5 Side Lighting
 The perfect cool spectrum supplement to your overhead LED light!

Triple Locking Door
 Maximum Safety & Security

Up to 40% Bigger Yields
 Exclusive Adjustable Net Trellis and Larger "Easy Access" Power Chamber

Continual Harvest Rotation
 Adjustable Vegetation Chamber can be raised, lowered, or removed

SuperCloner & MamaPonics
 30 Site Cloning & 8 Site-Mother Fully Automated for 100% Success

FEATURING: KIND LED GROW LIGHTS

700 mA Driving current diode efficiency and output, resulting in a brighter, higher yielding footprint

Proprietary 12 band complete "Perfect Spectrum" powered by 3-watt diodes

Secondary optical lens magnifies PAR and increases canopy penetration by up to 200%

Extra large heat sink, quiet fans, precision drivers, superior craftsmanship

Internal Circulation Fan

Adjustable for Perfect Airflow Everywhere

Superponics 3.0 Hydro System

Flower 1-18 plants up to 5x Faster and Earlier with Superponics

Three Year Warranty
 on your entire SuperCloset

Fully Automated
 Fully Assembled

Lifetime Customer Support
 7 days a week

Comes with EVERYTHING you need, including your Nutrients, DVD, Ph Kit, TDS Pen and More

P.O. Box 888665
 San Francisco, CA 94188

www.supercloset.com

tel. + 877. 476. 9787
 fax. + 415. 285. 0301



Smart-Dabb™
Your Dabbing Company
Smart-Dabb.com
858-312-5921
A LucyVapes Company

Smart-Dabb Classic

Smart-Dabb™ is designed with your health in mind. No torches, carbon monoxide gas, toxic fuel or burning yourself. Our **Electric Titanium Nail** reaches 700°F in under one minute! The perfect temperature to Dabb! Our nail is **100% Titanium**. The air passages are Food Grade Stainless Steel. The body is made from Carbon Fiber and Aircraft Grade Aluminum. The Glass joints are hand ground in Germany. **Smart-Dabb™** comes complete with 4 different adapters (so you are sure to find one that is a match to your water pipe), power cord, heating unit, titanium nail, straight sided glass dome and designer carrying case.



Visit our website to see all our Smart-Dabb™ products



Puff's favorite magic dragon treat!

MUNCHIES

Avocado Dragon Cake

Cali's two greenest treasures in one delicious dessert.

I first found out about avocado cake via an old recipe book of my mother's. This particular recipe's sinful combination of ingredients is as old-school as Wonder Bread, but it yields a modern-day stoner delight.

Though there's plenty of butter to play with in this cake, when I recently discovered that green dragon sugar can be made in two hours, I had to go that route. For an extra boost of green to this

already super-green cake, mix an eighth of shake or ground bud with the butter and heat in a double boiler for 40 minutes. Strain out the weed and let the butter come to room temperature. You can speed up the thickening process by sticking it in the fridge. Remember, getting über-baked is optional: Know thy tolerance and the tolerance of thy friends.

Also, you caught that part earlier, right? Two-hour green dragon sugar! A lab here in Oregon recently told a med-ible friend that the THC and cannabinoid levels are pretty much the same after two hours as two months. Leaving the plant in longer makes the tincture greener, but the lab says that's only chlorophyll. This is good news, as you can now make the sugar quickly as needed. Make this recipe by the batch, as you'll want your house stash of sugar to be stronger. This is to the dose. *Mary Ought Six*

DRAGON CAKE

$\frac{3}{4}$ cup Everclear
 $\frac{1}{4}$ oz ground cannabis buds
 1½ cups organic sugar
 1 cup mashed avocado
 1 cup unsalted butter, slightly softened
 1 egg
 $\frac{3}{8}$ cup milk
 2½ tsp. lemon juice
 1 tsp. cinnamon
 $\frac{1}{2}$ tsp. nutmeg
 $\frac{1}{2}$ tsp. salt
 1 tsp. baking soda
 1½ cups cake flour
 $\frac{1}{2}$ cup chopped walnuts
 8 large dates, chopped

Put the weed and Everclear in a glass jar and let soak. Shake the jar every half hour, including the first and last, for two hours. Discard the plant matter. Pour the infused alcohol over the sugar and mix well. Spread the sugar on a cookie sheet and bake at 150°F for around an hour, stirring

every 10 to 15 minutes until the alcohol is baked off. Remove from oven.

If you're using cannabutter instead of regular butter, make it while the weed is soaking so that it has time to firm up before you make the batter.

Mix the mashed avocado, green sugar, butter and egg until well blended. Mix the milk and lemon juice together separately. Add the cinnamon, nutmeg and salt to the batter while the lemon juice sours the milk. Dissolve the baking soda in the sour milk. Alternate adding the milk and flour to the avocado mix and then fold in the walnuts and dates.

Lightly coat a 9" x 12" pan with butter. Pour in the batter evenly. Use a spatula to clear the bowl and even out the corners. Bake at 300°F for one hour, then cut into 16 squares and enjoy! *Stones 16.*



www.drgreenthumb.com

Unique, high-potency genetics, available nowhere else. Home of the super-potent Endless Sky

Other fine strains include; Bubba Kush, Trainwreck C99, Sour Diesel, Iranian Autoflower, Headband U.K. Cheese, Chemdawg, Bubba OG, G13, OG Kush

ALL OF OUR FEMINIZED SEEDS ARE GUARANTEED 100% FEMALE.
 ACQUISITION OF LIVE CANNABIS SEEDS IS ILLEGAL IN THE UNITED STATES
 PAYABLE IN US DOLLARS FROM ANYWHERE IN THE WORLD.

New! Low Odor INCOGNITO Low Odor New!

Hardly any smell until you stick your nose right into the buds.
 Big lemon citrus flavour with floral notes in the smoke.
 Big yields and superior potency

For a catalog, including a \$10 off coupon, send \$5 to:
 RWJ, Box 37085, Ottawa, ON, k1v0w9, Canada

Information or garden support call; 613-330-2404

**Free World-wide Shipping
 Trusted Since 1996**



Easily Make MagicalButter.com®

Gummies

How to

- Step 1** Put your tincture in a 1-quart non-stick saucepan and heat on low. Cook until almost all of the alcohol has evaporated (approx. 5 minutes). It should look like molasses.
- Step 2** Add emulsion, sweetener, reduced juice, and extract and stir. Remove from heat and let cool for five minutes.
- Step 3** Add cold juice. Then slowly add gelatin, starting with the unflavored. Sprinkle around the top evenly, and repeat with the flavored jello. Then whisk to combine and let sit for 10 minutes.
- Step 4** Put back on the stove on medium heat, and cook around 5-7 minutes, until gummie mixture dissolves and looks clear.
- Step 5** Pour into a glass measuring cup. (The pouring spout will make it easy to put into your molds.)
- Step 6** Pour into molds. Let cool in freezer for 15-20 minutes.
- Step 7** Remove from mold and eat.

Ingredients

- 1/2 cup MagicalButter tincture (we recommend using alcohol tincture, cook off the alcohol and add 1/4 cup reduced juice)
- 1 1/2 cup Pom Wonderful Juice, or your favorite juice. (1 cup of juice will be reduced to 1/4 cup)
- 1/2 teaspoon lemon emulsion (We recommend LorAnn brand)
- 1 teaspoon flavoring extract, to complement flavor of the gummies you're making
- 4 tablespoons of Monk Fruit or Stevia Sweetener (I recommend using "In The Raw" brand)
- 4 - 1/4 ounces unflavored gelatin
- 2 - 3 ounces flavored jello of your choice



ARE YOU READY FOR THE
PUREST TASTE POSSIBLE

from oils & extracts?



Many connection
options

All-ceramic
body

Robust control
with 700° & 900°
settings

Introducing the VB2™
a first of its kind

Learn more at vaporbrothers.com

VAPORBROTHERS®
original vapor equipment



The New VB2 for Oils



Vaporbrothers'
Original Vaporizer



Dabblers™ by Vape-Pen®

©2014 by Vaporbrothers Inc. Patents Pending.

The War's Unhappy Birthday

By Chris Simunek

It's often the case that when tragedy occurs, a nation will take advantage of the subsequent outrage and confusion to grab land, resources or power, much like looters emptying out an electronics store in the middle of a riot. Such was the case after 9/11, when America enacted the Patriot Act, began illegally eavesdropping on millions of its citizens, and started two ill-conceived and intractable wars in Afghanistan and Iraq.

Iraq was probably the larger debacle, a conflict that America lied its way into, citing Saddam Hussein's nonexistent nuclear- and chemical-weapons programs and phantom links to 9/11. We can condemn Saddam's brutal reign all we like, but the obvious fact is that the United States attacked that country without any plan for keeping the peace among its disparate ethnic and religious factions once he was gone. Now, a year and a half after the exit of American troops, Iraq is engaged in a full-on holy war, staggering enough in its level of violence as to make the deceased dictator look like a neighborhood thug by comparison.

Unlike the invasion of Afghanistan, Operation Iraqi Freedom met with massive resistance stateside, which I covered in "Let 'em Eat Freedom Fries" in our July 2003 issue. It's now been historically proven that those of us who opposed the Iraq War were right, and those who dragged us into it were

wrong. The statements made at the time by the neocons who engineered the invasion would be laughable now if those same people weren't responsible for the deaths of nearly 5,000 US troops and well over 100,000 Iraqi civilians.

"I can't tell you if the use of force in Iraq today would last five days, or five weeks, or five months, but it certainly isn't going to last any longer than



that," Donald Rumsfeld announced in 2002. "Iraqi democracy will succeed, and that success will send forth the news, from Damascus to Tehran, that freedom can be the future of every nation," Bush proclaimed in 2003. Those of us with a firmer grip on reality predicted the current catastrophe. We marched in Washington, or stood in massive cattle pens along First Avenue in New York City, and ultimately watched impotently as our leaders planted the seeds of the chaos that is in full bloom today.

High Times' founder, Tom Forcade, was a product of the radical movement that opposed the Vietnam War. And we have always called out America's leaders for their corrupt military campaigns, whether it was the covert war against leftists in Central America, the war against Saddam in Iraq, or the war against marijuana here at home. There are plenty of news outlets these days that provide (supposedly) objective reporting. At *High Times*, we prefer to tell the truth. 🌿

CANNABIS CUP WINNING NUTRIENTS

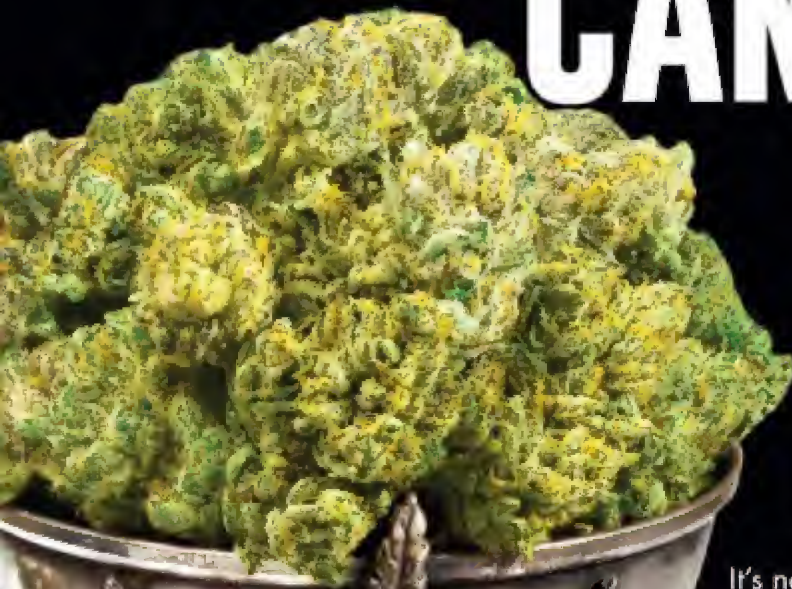

It's not that we enjoy bragging, however the fact of the matter is there are no awards or categories for best nutrient companies at the major growing competitions. And because there's no award, and it's something we are proud of, we want to share this little known fact with you...

Advanced Nutrients has been used to repeatedly win every single major grow competition in the world and in all categories. Best Hybrid, Indica and Sativa. Best Hash and Concentrates. Plus, seed companies Barney's, Big Buddha and Rare Dankness (to name just a few) use Advanced Nutrients to grow their award winning seed crops.

Here's a list of some of our wins:

- High Times® Cannabis Cup®
- High Times Medical Cannabis Cup Los Angeles
- High Times Medical Cannabis Cup San Francisco
- High Times US Cannabis Cup Denver
- High Times US Cannabis Cup Seattle
- Kush Cup
- Spannabis
- 43th Annual Hash Bash
- HempCon.
- Highway 420 Anti-Prohibition Rally
- Expocannabis Sur
- Cannabizz
- Nimbin MardiGrass
- Global Marijuana March
- Emerald Empire Hempfest
- Olymia Hempfest
- Hanfparade
- Hempfest Seattle
- Cannatrade
- Expogrow
- Boston Freedom Rally
- Cultiva Hanfmesse
- Cannafest
- Treating Yourself Expo
- Secret Cup
- Grow Med
- 707 Cup
- The 16th Annual Marijuana Concert

"I would not be where I am today - as far as quality - if it wouldn't have been for Advanced - honestly"

— Mr. Spliff of TGA Seeds, High Times Medical Cannabis Cup WINNERS

"I tried many other brands and they never won a cup for me until I started using Advanced Nutrients. Now I rely on their entire line to win cup after cup"

— Rocky, Champs Cup WINNER

CAUGHT ON CAMERA:

See not one, not two, not three, but FOUR different Cannabis Cup WINNERS praise Advanced Nutrients and share their favorite products in this "behind the scenes" video from Los Angeles High Times Medical Cup 2013:

ChampionGrowersUseAdvanced.com

Photo: High Times® Photographer Lochfoot

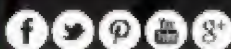

Ask your local hydroponic retailer about what Advanced Nutrients can do for your garden today!

 **Advanced Nutrients**
Revolutionizing Plant Potential

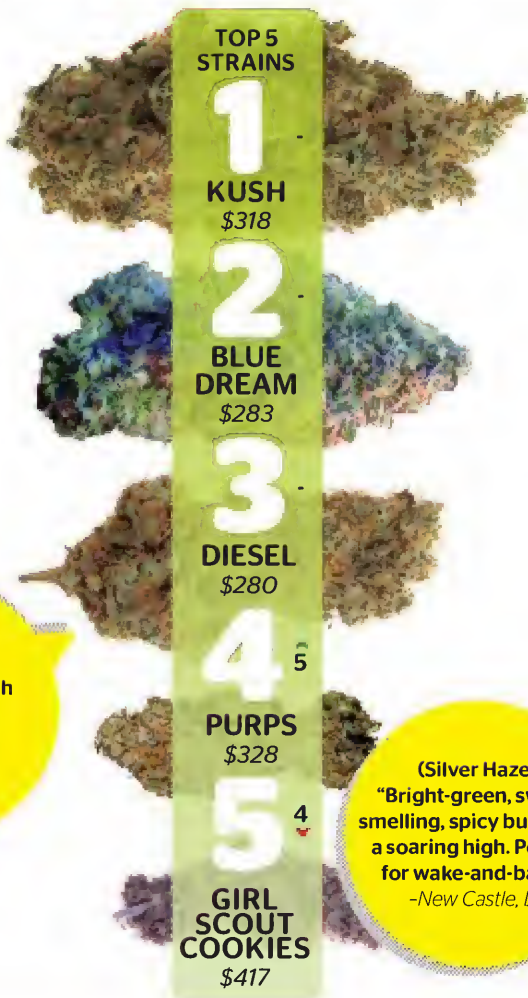

(Sour Kush)
"Clear, precise high ... great for joint ailments!"
-Springfield, MO

(Silver Haze)
"Bright-green, sweet-smelling, spicy buds with a soaring high. Perfect for wake-and-bake."
-New Castle, DE

TRANS HIGH MARKET QUOTATIONS

STATE	CITY	STRAIN	PRICE
Alabama	Birmingham	Green Crack	\$360
Arizona	Tucson	Skywalker OG	400
Arkansas	El Dorado	Blue Dream	400
California	Sacramento	Blue Dream	150
	San Francisco	Grand Daddy Purps	250
Colorado	Colorado Springs	Sour Diesel	225
	Denver	Headband	165
Delaware	New Castle	Silver Haze	350
Florida	Miami	Girl Scout Cookies	500
	Tallahassee	Silver Haze	320
Georgia	Augusta	Purps	480
Indiana	Indianapolis	Bubba Kush	350
Kentucky	Fort Campbell	Purple Kush	360
Maine	Portland	East Coast Sour Diesel	330
Maryland	Elkton	Jilly Bean	375
Massachusetts	Boston	Strawberry Cough	320
Michigan	Benton Harbor	Blue Dream	225
	Detroit	Larry OG	350
	Flint	LA Confidential	200
Minnesota	Minneapolis	Cheese	350
	St. Paul	Purple Urkel	400
Mississippi	Canton	Blue Dream	325
Missouri	Springfield	Sour Kush	300
Nevada	Las Vegas	Holy Grail Kush	350
New Hampshire	Concord	Sour Diesel	325
New Jersey	Hoboken	Chemdog	400
New York	New York	Girl Scout Cookies	350
North Carolina	Raleigh	Green Crack	400
Ohio	Columbus	JillyBean	320
	Coshocton	Green Crack	200
Oregon	Portland	Cheese	180
Pennsylvania	Philadelphia	G-13	375
Tennessee	Memphis	OG Kush	350
Texas	Austin	Blue Dream	320
Virginia	Richmond	White Widow	400
Washington	Toppenish	Trainwreck	250
Wisconsin	Milwaukee	Blue Dream	300
INTERNATIONAL			
Australia	Queensland	Purple Haze Skunk	AU\$280 250
Canada	Milton	OG Kush	C\$240
	Vancouver	Jack Herer	170

MARKET ANALYSIS

Prices by the ounce

The US Price and Kind indices essentially held steady in October after significant drops in average price last month. The Mids Index, however, dropped \$36 from its previous month's average, plummeting all the way down to just \$248 an ounce. That marks a 53-month low for Mids, as the index last finished at \$248 in May 2010.

US Price Index
YTD Average: \$305



Kind Index
YTD Average: \$382



Mids Index
YTD Average: \$272

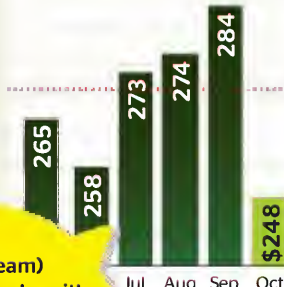

Schwag Index
YTD Average: \$101



(Blue Dream)
"Awesome smoke with great pain-relieving qualities. I noticed significant relief after two small tokes."
-Canton, MS

(Chemdog)
"Quite possibly the stinkiest weed I have ever encountered ... incredible!"
-Hoboken, NJ

High Times wants to know what you're smoking. Submit your strain information including location and price by the ounce to thmq@hightimes.com - or tweet us (#THMQ).



WARNING: CANNABIS IS AN ACCUMULATOR PLANT ...

Did you know Cannabis was used at the Chernobyl site to help pull radioactive contaminants out of the soil?

They used Cannabis for soil remediation because it's an accumulator plant that absorbs nearly everything in its environment. While soil remediation sounds great, the fact is, the cannabis plants were now highly radioactive and had to be disposed of properly as well.

COULD YOU IMAGINE A PATIENT SMOKING RADIOACTIVE WEED?

It's a scary thought, isn't it? In short, cannabis accumulates everything in its environment—including potential toxins—and retains them even after harvest.

In other words, whatever your plants accumulated while growing—you are now smoking. That's why you need to know how to protect yourself and your patients from potential medical marijuana toxicity.

The entire story, along with many other little-known, yet vitally important facts are revealed in a new Bulgarian Academy of Sciences white paper titled:

"HOW TO PROTECT MEDICAL MARIJUANA PATIENTS FROM HEAVY METAL TOXICITY ... WHILE RAISING BUD WEIGHT, THC, AND CANNABINOIDS"

The author of the white paper, Julian Karadjov, PhD, reveals facts medical marijuana growers absolutely **MUST** know. Here are just a few ...

- The little-known fact that makes Cannabis totally different than other plants and why not knowing this can endanger the lives of your patients!

- Why the nutrients you feed your plants

could actually be turning them toxic (make sure you check your bloom boosters for this one common ingredient that could be toxic)

- Exactly which heavy metals are toxic and how to protect your patients from ingesting them (There are some heavy metals that are completely harmless. Get the complete list inside!)

- Surprising plant tissue sample results of Berlin, Hash Plant, and White Rhino strains of medical marijuana (goes completely against what most growers think is needed to maximize size, weight and potency!)

- The TRUTH about so-called "Pharmaceutical Grade" salts and chelates

- Why you can't trust regulators and other government "watch dogs" to make sure the hydroponics nutrients you feed your plants are safe

- The 2 biggest MYTHS about natural and synthetic chelators and their role in toxic metal absorption.

- How to guarantee—with 100% confidence—that your medical marijuana is a pure and harmless as filtered drinking water!

- How the University of Mississippi achieved 21% more yield from their cannabis plants with one simple change to their feeding program

- How to nearly DOUBLE the amount of THC and other cannabinoids your plants produce the very next run you start (new test results from Hedron Analytical Inc.)

- As Seen On TV: the dangers of Medical Marijuana Cadmium poisoning (and how to help your patients completely avoid this risk!)

And there's more too ... The dangers of "home brew" hydroponics nutrient formulations ... African Marijuana cadmium dangers ... plus other little-known facts most growers never hear about.

The bottom line is: if you grow medical marijuana and care about the safety of your patients at all (or you use marijuana yourself) then you must read this white paper.

It's free to access and available online. Simply visit

AdvancedNutrients.com/HeavyMetal

to download your copy today.



 **Advanced Nutrients**
Revolutionizing Plant Potential

1



2



3



4



Hot Products

What's new for cannabis cultivators and connoisseurs.

1 Pax for Flowers

\$249.99
ploom.com

Vaporizer technology took a giant leap forward when the folks at Ploom got into the game. The design and functionality of the Pax makes it the best handheld vaporizer for flowers, bar none. Simple, innovative and discreet, this vaporizer has it all. Charge it up and your Pax is ready to travel, giving you hit after tasty hit of vapor set to your desired temperature.

2 Blissful Plants

1 oz, \$56; 4 oz, \$179; 8 oz, \$309
organibliss.com

Marijuana growers interested in improving their plants' health and yields should look no further than the Organibliss natural plant supplement. This OMRI-listed and highly concentrated liquid consists of pure neem extract in addition to the essence of robust plants from sub-Saharan Africa. Used as a foliar spray, this magic mixture helps repel pests while producing heavier harvests.

3 The Ultimate Pen

Pen, \$40; 0.5-gram injector, \$50; 1-gram injector, \$100
gfarmalabs.com

Not only will the GFarma crew hook you up with a great vape pen—if you're a registered patient in a medical marijuana state, they'll fill it with pharmaceutical-grade, CO₂-extracted Liquid Gold cannabis oil, which comes pre-packaged in injectors and is available in *indica*, *sativa* or hybrid-specific formulations.

4 Frosty Freeze

\$89.99
eycemolds.com

Everyone loves smoking from an ice-cold bong, but nothing could prepare us for the sensation of puffing out of an Eyce Molds water pipe made entirely from ice. The kit comes with a stand, mouthpiece, downstem, silicone mold and everything else you'll need to build your bowl. Simply fill it with water, pop it in the freezer for a while and then enjoy your new ice-cold pipe.



DON'T GROW BLIND™
 COLOR • CLARITY • PROTECTION



METHODSEVEN.COM

DEALZER.COM Order Today, Grow Tomorrow! 888-HYDRO-81

GROW YOUR OWN!
 HYDROPONICS GROW BOXES FROM \$420

GRANDMA'S SECRET GARDEN ADD CO2 ENHANCER FOR ONLY \$49
\$649 36" T x 20" W x 18.5" D

Grow ANY plant indoors from seed to harvest!
 We provide everything. All you need are plants or seeds!

CASH CROP GROW BOXES

\$420 UPGRADEABLE TO 3FT TALL FOR \$75
 ADD CO2 ENHANCER FOR \$49
 36" T x 18" W x 9.5" D



MAGIC HERB DRYER

24" T x 24" W x 20" D

\$239



WORLDWIDE SHIPPING AVAILABLE!

Regulatory. Please contact us for wholesale pricing.



DO YOU OWN A HYDROPONICS STORE AND NEED TO BUY IN BULK? CALL 888-HYDRO-81 FOR WHOLESALE PRICING ON OUR POPULAR GROW SYSTEMS. (DROPSHIPING ALSO AVAILABLE)

Buy online or call to order! Over 50 grow boxes, grow tents, and grow lights available online!

www.Dealzer.com 888-HYDRO-81 (888-493-7681)

Oil Slick®

TOOLS TO HELP YOU CONCENTRATE



SLICK™ PAD



SLICK™ TUBE



SLICK™ STACK



SLICK™ BALL



SLICK™ BALL MINIS



SLICK™ SLAB



SLICK™ SHEET



SLICK™ STACK MICRO

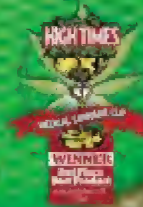

OILSLICKPAD.com

High Times and Cannabis Cup are trademarks of the Trans- High Corporation and used with permission.



Legalization and the cannabis industry's exponential growth means that there's no shortage of opportunities to get your foot in the door. Check out our top pot jobs and start working now! *By Jen Bernstein*



Cannabis legalization has created thousands of new jobs. For the first time in American history, an economy based on growing, selling and using legal marijuana exists. In fact, the industry is developing at such a rapid pace that it's hard to put a number on just how big it is.

In the first two months after legalization, Colorado made \$3.4 million in new tax revenues, with initial projections estimating another \$184 million over 18 months. As more states legalize cannabis, we could be looking at a \$10 billion industry by 2018.

"Over 10,000 marijuana-industry jobs have been created in Colorado alone," says Dan Kingston, founder of *420Careers.com*, a cannabis job board that posts five to 10 new job listings a week.

"And thousands more will be created as more states legalize."

Kingston, who resides in the medical-marijuana-friendly state of Arizona, has seen firsthand the exponential growth of pot-related jobs. "Graduates coming right out of school typically can't find a job in their field of study, so they're coming in droves to entry-level jobs in medical marijuana," he notes.

High Times, celebrating its 40th anniversary this year, has been in the business of cannabis from the beginning. Taking advantage of the many relationships we've cultivated over the years, we recently sent out our first *High Times* Cannabusiness Survey to determine the financial temperature of the industry; the results are shared here. And since so many people want to know how to get a job in the cannabis industry, we've compiled ideas and advice on ways to get started.

5 Tips For Success

1) Determine your interests

There are many ways to enter the industry, and hundreds of different jobs—but what appeals to you? Do you love to grow? Have an aptitude for business or a flair for sales? Knowledge and a passion to learn everything you can about your field are important. Employers are always impressed in an interview when you know about their work culture and how they operate.

2) Know your skills

It's useful to envision just how you can succeed. For example, there are plenty of people who grow really good weed, but maybe you can grow really good weed *and* code software. Examine what you do best and then offer up your unique skill set.

3) Invest your time

If you don't know much about the industry or don't have a unique skill to set you apart from the competition, try joining an organization that supports the cannabis movement. Volunteering your time shows a deep level of commitment that makes you attractive to employers. And while volunteering, you'll be networking: You'll meet industry leaders, up-and-coming entrepreneurs—and potential employers.

4) Invest your money

If you have the means and don't want to miss out on lucrative ground-floor opportunities, look into investing in things like real estate for cannabusinesses, or cannabis-extract or agricultural equipment. Attend industry trade shows and, if you see potential in a cannabusiness, offer to become partners for a percentage or stake in the company. If you're an accredited, large-scale investor check out venture-capital groups like the High Times Growth Fund which pairs potential investors with existing businesses, or an investment network like the ArcView Group which hosts *Shark Tank*-like pitch sessions where they hear from potential entrepreneurs and then connects them with investors. Buyers beware: Pot stocks are high-risk investments and extremely volatile—so think again if you're trying to get rich quick.

htgrowthfund.com; arcviewgroup.com

5) Get a higher education

If you're really green and want to start out in the industry, then go to school. High-school graduates should look into universities that have a college of agriculture and life sciences, like Purdue, Texas A&M, or Iowa State. If you want to be closer to the heart of things, the University of Humboldt in California has an excellent botany program.

However, those colleges won't teach you how to grow marijuana or run a cannabusiness. For that, you'll have to attend institutions of higher learning. Every month, Oaksterdam University in Oakland, CA, offers basic and advanced indoor horticulture seminars, which include four days of intensive instruction, and 26 hours of grow training from expert teachers. They also hold seminars across the country. 420 College offers weekend seminars on how to open a dispensary, as well as workshops on cultivation training, across the US. And at the Cannabis University of Colorado, students can attend the All-in-One-Day class for \$250, which covers everything from growing your own meds to understanding Colorado state law.

oaksterdamuniversity.com; 420college.org;
cannabisuniversitycolorado.com

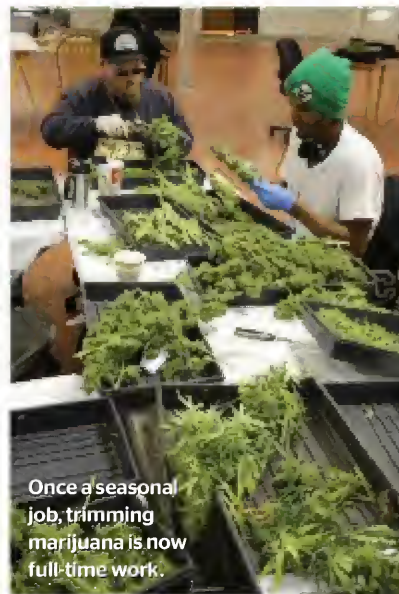

Once a seasonal job, trimming marijuana is now full-time work.

13 Top Pot Jobs

Colorado, California, Washington and Arizona are currently the easiest states to find employment in. And as more states approve medical marijuana or move toward legalization, more opportunities will be created. Here's our baker's dozen of top pot jobs:

1) Trimmer

Someone has to manicure that lovely, sticky weed into the beautiful nuggets you purchase at the dispensary, so why not try your hand at it? This entry-level position isn't glamorous, but it *is* essential to every large-scale grow operation. Teams of trimmers work their way through pounds of bud and are paid hourly, or by the weight of their finished product. Whether you're a full-time employee or freelancer, trimming bud is an excellent way to learn the ins and outs of the trade. Sammy Saltzman, who has risen through the ranks of Denver's dispensaries, recommends Hemp Temps, which staffs cannabis companies. "Hemp Temps will schedule you at a warehouse, or you'll trim for the dispensary they assign you to," Saltzman says. "If you're looking for full-time work, you can network at your temp job with the hopes of maybe one day getting hired by a dispensary that likes you and your work ethic."

hemptemps.com



Budtenders make recommendations based on a patient or consumer's needs.

2) Budtender

This dispensary or co-op employee works behind the counter, listening to customers, and recommending strains to match their preferences. Good budtenders are patient, and develop a rapport with their clientele. Handling and dispensing weed doesn't have to be done by an expert, but you do need a state license; in Colorado, budtending positions are fairly easy to come by, but getting a license is not. The state's Medical Marijuana Enforcement Division application process is backlogged. Applicants are photographed, fingerprinted, and pay a \$75 fee. Oh, and you have to pass a background check too.



EGC/AFS Phoenix AZ

EGC/AFS Phoenix AZ

Health for Life, Mesa AZ

growlite



OG FOR
A REASON

www.growlite.com

3) Grower

Becoming a marijuana grower is one of the most rewarding—and confusing—paths one can take in the legal marijuana industry. Laws differ from state to state, and in California, from county to county and sometimes even city to city. Under California law, you're only allowed to grow your allotted amount as a caregiver or as part of a collective. California cannabis consultant Liana Held suggests anyone interested in growing, "speak with a lawyer and set up a not-for-profit mutual benefit corporation. You can grow six mature, 12 immature and possess eight dried ounces for each



Expert cultivators are the backbone of the cannabis industry.

person in your collective. Once they are supplied, you can sell the overage to a dispensary." As far as dispensaries go, it's a buyer's market, and it's likely you will walk away disappointed at the amount you were paid for your "legal" bud.

Then there's Washington, which voted to legalize recreational marijuana. There was a brief window to submit license applications to become a producer, packager or retailer in the industry. The state received over 2600 applications, and has thus far approved only 70. There is going to be a great need for experienced cultivators as more are approved. A grower looking for work can go to the Washington State Liquor Control Board website and search public records to see the name, addresses and approval status of each company.

Since medical marijuana businesses are vertically integrated in Colorado, Ryan Cook, general manager of The Clinic, recommends growers who have obtained an occupational license to send their resumes directly to medical and retail marijuana centers to get started. canorml.org; liq.wa.gov; colorado.gov

4) Caregiver

With medical marijuana legal in 22 states and the District of Columbia, becoming a caregiver may have crossed your mind—especially if you have a genuine interest in helping patients who can benefit from cannabis's medicinal qualities. Though the definition varies from state to state—and not every state allows for caregiving—a caregiver is someone who can grow, possess and provide medical cannabis for a registered patient or patients. If you're interested in learning more about becoming a licensed caregiver, visit your state's government homepage or go to:

marijuana-caregiver.com.

“Every once in a while, a product emerges that we clearly see will revolutionize the industry. Each time, we see these products first in the pages of High Times or at one of our High Times Cannabis Cup expos. We are a portal for people looking to get into the business of pot.”

—Danny Danko, *High Times* senior cultivation editor

5) Product Manufacturer

Among stoners, there's no shortage of ideas—all it takes is one good hit and the creative juices start flowing! So take that great idea for a pot product and turn it into profit. To make your dream a reality,

first figure out if there's an actual need for your product. Poll your friends, get feedback, and fine-tune your inspiration. Before you apply for a patent, you'll need to have a finished product—that means building and testing your invention. Then you'll need to file an application with the US Patent Office. When it comes to retail, the High Times Cannabis Cup is a great place to start turning your idea into cash.

6) Edibles Chef/Cook

Do you love to bake? Why not apply your culinary skills to the cannabis industry? Personnel with a kitchen background are in demand; many patients and consumers prefer to eat cannabis rather than smoke it. CNN Money recently profiled Joe Hodas, Dixie Elixir's chief marketing officer, who said: "As demand for the product grows and stigma falls, I see the [edibles] industry as a tremendous potential creator of jobs." Dixie Elixir is poised to expand operations into Arizona this year. In Colorado, manufacturers of edible medical-marijuana-infused products must have a food-handling certificate and complete a basic training course. Regulations vary from state to state but to work for any Colorado cannabis company, employees must also have a MMED occupational license.

7) Lobbyist/Activist

One entry-level cannabis-industry position that's in demand is as petitioner. Full-time positions aren't numerous, but there are plenty of projects that need signatures gathered to gain ballot access for pro-pot initiatives. Whether you're looking to get involved at the local, state or federal level, Allen St. Pierre, executive director of NORML, says that many cannabis policy reform groups seek public participation. He recommends norml.org for legalization, votehemp.com for hemp and safeaccessnow.org for medical cannabis. With more than 150 state and local chapters, NORML is the "backbone of the cannabis law reform movement," says St. Pierre.

8) Lawyer

Since Washington legalized recreational cannabis use, the Seattle law firm of Harris & Moure has been inundated with new clients. Harris & Moure lists its services under the Canna Law Group and specializes in cannabis-related regulatory compliance, applications, taxes and insuring businesses; it has also branched out to include trademark and copyright protection. Though other cannabis-related legal firms are rare, Allen St. Pierre says

OCTOBER

Supreme Reflector
PRODUCT OF THE MONTH
\$79.99
WHILE SUPPLIES LAST
HIDHuf.com



NOVEMBER

Glass Tube Reflector
PRODUCT OF THE MONTH
\$49.99
WHILE SUPPLIES LAST
HIDHuf.com



DECEMBER

Mini Drying Rack
PRODUCT OF THE MONTH
\$19.99
WHILE SUPPLIES LAST
HIDHuf.com

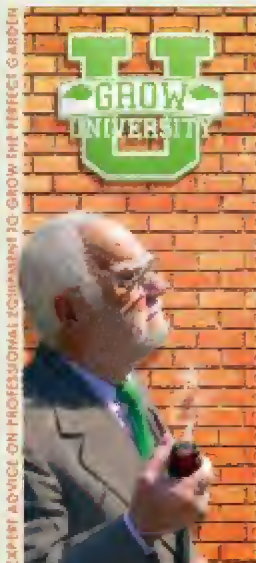

Bubble Easy 5 Gallon
\$149.99

MYLAR 50" x 50" **\$29.99**
MYLAR 50" x 100" **\$59.99**

Recipe for Success
\$39.19

CO2 Regulator
\$79.99



Large 35" Diameter
6 Tier Drying Rack
\$39.99

5 Site DWC **\$79.95**
4 Bucket DWC **\$179.99**
5 Bucket DWC **\$199.99**

24" x 24" x 55" **\$ 99.99**
40" x 40" x 77" **\$159.99**

600W Grow Light Kit
\$174.99

600W Digital Ballast
\$119.99

150W HPS **\$19.99**
250W HPS **\$22.99**
400W HPS **\$24.99**
600W HPS **\$34.99**
7000W HPS **\$44.99**

4" Cannon Fan **\$99.99**
6" Cannon Fan **\$119.99**

4" Cannon Filter **\$49.99**
6" Cannon Filter **\$99.99**

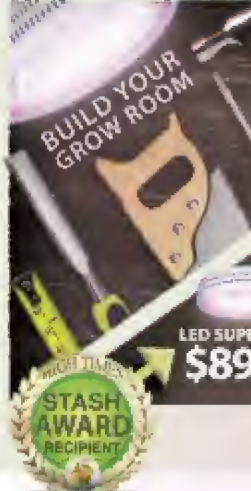

LED SUPERNOVA **\$899.99**
LED COMET 150 **\$149.99**
LED COMET 400 **\$349.99**
LED COMET 150 **\$399.99**

Purchase all your gardening supplies and more at HIDHuf.com
For product details and ongoing promotions, visit us online or call: (866)678-8565



GET YOUR FREE PRODUCT BROCHURE

The Results Are In

Examining the numbers of our new industry.

What is your primary business?

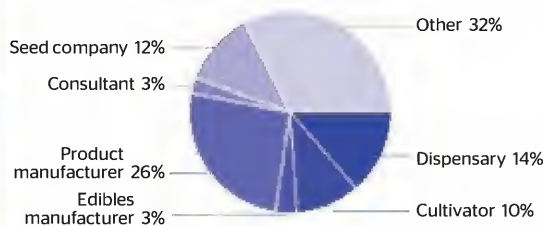

How did you fund your cannabis business?

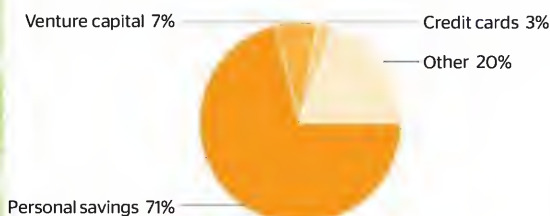

How much were your start-up costs?

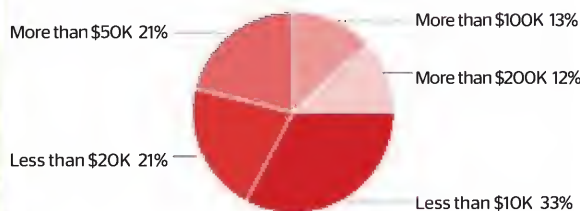

What were your main start-up costs?



What is your annual revenue?

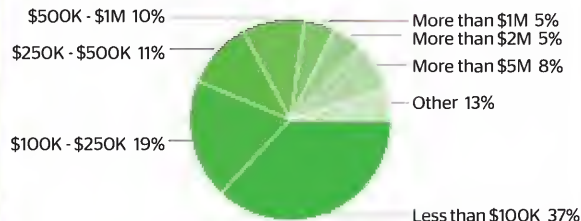

How old are you?

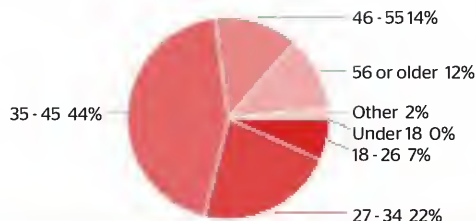

the SF law group Pier Five Law does great criminal and appellate work—and he speaks highly of the firm of Evans & Cutler in Massachusetts. For those fresh out of law school, St. Pierre recommends branching out into cannabis law reform by joining NORML’s Legal Committee; attending NORML’s annual legal seminars; and volunteering with a NORML chapter to help challenge cannabis prohibition laws and draft reform legislation. cannalawgroup.com

9) Writer

If you’re reading this article and thinking, “Hey, I could’ve written this,” chances are ... you’re probably right! Websites, blogs, and news organizations are all covering the cannabis industry and its ever-changing landscape. Ricardo Baca was the *Denver Post’s* music and entertainment editor for 12-plus years before he was selected as the newspaper’s first marijuana editor. If you have an idea for a story or think marijuana is your beat, pitch your local news editor, or create a blog. Use your posts as a portfolio to showcase your beautiful, flower-y prose. And if you think you’ve got what it takes to write for *High Times*, email us at: managingeditor@hightimes.com.

10) Accountant

Every cannabis business needs a professional who can keep accurate books. From loans to private equity, cash management, payment processing and handling taxes, accountants who understand the industry will increasingly be in demand. Seminars and events tailored to marijuana financials, such as the CannaBusiness Money Show, are offered through sites like Marijuana Business Daily. mmjbusinessdaily.com/money

11) Security

With more than 500 medical and retail dispensaries in Colorado, security is a major concern for cannabis business owners—especially when they’re dealing in cash-only sales and a product that is considered illegal by the federal government. Kyndall Cowan of Canna Security America says that because of high demand, CSA now offers armed guards and vehicles with bulletproof windows. “Getting the product from the grow to the dispensary is a huge safety concern,” she says. Dispensaries can also hire

security staffed by former military or law-enforcement officials (which bodes well for veterans looking to get into cannabis-related business). Video surveillance is also required by law, and must be installed and operated in any area that contains marijuana (cashiers’ spaces, safes, parking lots, growrooms, etc.), so the time is ripe to learn how to install and maintain surveillance units. cannasecurity.com

12) IT/Computer Programmer

Know a thing or two about ones and zeros? Take your code-writing skills to cannabis business. It’s standard operating procedure for any successful business to maintain a website with up-to-date information. Colorado’s demanding seed-to-sale laws require every step of cultivation to be tracked—and software like MJ Freeway has helped revolutionize and streamline data. But the industry needs IT professionals to make it all work. The cannabis-specific job board WeedHire regularly lists open positions for e-commerce managers, tech bloggers and programmers, so be sure to check frequently for new posts, or set up a job alert to notify you. weedhire.com

13) Consultant

If you know how to set up a grow-room, why not help others get started? Maybe you’re really good at managing an office, or marketing a product. Whatever it is that you do like a pro, there may be a cannabis-industry consultant position for you.

Kenny Morrow of Trichome Technologies is a grower with 30 years of experience in large-scale cultivation. We asked him how a consultant might get a foot in the door. “The first thing you need is a background in the field. You need a solid resume, great references and verifiable real-life experience. Then you need to find a client. I suggest you go to cannabis conferences and trade shows, like the various High Times Cannabis Cups, or the National Cannabis Industry Association’s Cannabis Business Summit. Oaksterdam University is a good place to get experience and to network and they have travelling conferences throughout the country. The most important thing is hit the bricks and advertise your services.” cannabiscup.com; thecannabisindustry.org; oaksterdamuniversity.com



PURE ESSENTIALS

BLACK LABEL

THE **HEARTBEAT** OF YOUR GARDEN



VISIT US ON THE WEB AT
GROWBLACKLABEL.COM

AVAILABLE AT QUALITY INDOORGARDENING STORES EVERYWHERE





PROFILE: Brooke Gehring
COMPANY: Patients' Choice, Live Green Consulting
OPERATIONS: Four locations in the Denver area

Brooke Gehring was a commercial banker before making the bold decision to leave corporate America for the cannabis industry in the summer of 2009. Currently, Gehring operates Patients' Choice of Colorado, a medical marijuana company with four dispensaries (three recreational and one medical) in the Denver area.

What did you do to get your foot in the door?

I was persistent and curious. I had to network and introduce myself to people—professionals, public figures, policymakers, legislators and anyone else willing to talk about marijuana as a business. I once sat through a five-hour-long City Council meeting in Denver just for the chance to introduce myself to one council member.

What skills did you have that set you apart or helped you?

My experience of being a director of compliance for a national brokerage company during the rise and fall of the market gave me a solid foundation for understanding regulations and how licensing authorities work and enforce rules under state and local governments. I also had corporate retail experience that helped me out immensely when setting up the front end of the dispensary business.

Did you take any classes or further your education?

All of my learning in this industry has been in addition to my undergraduate studies. Keeping up to date on all of the current regulations, understanding the legislative process, attending council meetings, being proactive on the policy boards and participating in the state rulemaking process has been my way of educating myself on how to operate a compliant and successful multi-city marijuana company.

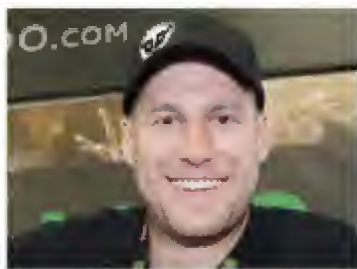

PROFILE: Tony Verzura
COMPANY: RiverRock
OPERATIONS: Two locations in the Denver area

Tony Verzura was studying film in 1996 when he was injured in a car accident and prescribed oxycodone. Verzura weaned himself off the habit-forming pharmaceutical with cannabis and had changed career paths when a lawyer friend called him in 2009 with a business proposition. Together they created RiverRock, a professional caregiver service.

What did you do to get your foot in the door?

I created the door—and the opportunity—from 250 bucks and a business plan.

How was RiverRock funded?

I started RiverRock with three lights and six plants and then expanded into a few basements prior to getting the facility where we're currently located. In order to get that facility, we had to pitch the idea to family, friends, and to businessmen that wanted to take a chance.

Did you build a team of people to help you?

We went from two or three people to more than 80 employees and consultants working under one roof at RiverRock. We assembled teams for processing raw medicine into concentrates, hash, topicals, edibles, pills and transdermal products. We assembled a legal and compliance team along with a full-blown in-house construction team.

What were some of the challenges when you were starting up?

It seems like every three to six months, this industry changes so much that it's a miracle any business could survive. Today, the biggest challenge is not keeping up with the regulations, rules, tracking and testing requirements, but the ability to bank and run our businesses without tax laws subjecting us to unfair rulings that have nothing to do with our Colorado business models.



PROFILE: Sam
COMPANY: Dab OTG
OPERATIONS: Dab-pen sales

Sam and his business partner Ben created Dab OTG. The company began taking out ads in *High Times* and selling vape pens from its booth at the 2013 US Cannabis Cup in Seattle. "After Dab OTG was named Best Overall Pen in the January 2014 'Vapor Pen Review' issue," says Sam, "we couldn't keep the glass in stock."

What did you do to get your foot in the door?

Having a degree in business definitely helped me to start the company, but I met my partner while doing something I love—and that's seeing live music at Terrapin Crossroads. It was coming up with an innovative idea that opened the door for us. Getting in touch with *High Times* helped us a lot, too—it's a good, solid connection in the industry.

What were some of the challenges when starting your cannabis business?

It was hard to find dependable people to help create our product. Since we sold out of our product so quickly, another initial challenge was keeping our inventory up. We were only a couple of months old when we were named "best pen," but through those sales we were able to reinvest back in the company and stock up on inventory.

What advice do you have for people starting a cannabis business?

Think about something new or better that you can bring to the industry. If you're trying to start your own company, then do it on your own—but if you don't have the means, find someone else who can help you. For us, we try to remember where we came from ... and that was standing in front of Phil Lesh, bassist for the Grateful Dead.



PROFILE: Butcher
COMPANY: SourBhotz Medibles
OPERATIONS: Oregon dispensaries

For the New York City born-and-bred Butcher, getting started in the cannabis industry meant saying goodbye to everything he knew and loved on the East Coast, cashing out his personal savings and moving to Oregon. "Having been in the food industry for 15 years and knowing my way around the kitchen was a huge asset in creating and developing ingestible cannabis products," he says. "As of now, I'm a one-man army as far as producing, packaging and marketing my edibles."

What did you do to get your foot in the door?

First, I made sure to have a solid product and branding. With the R&D and marketing strategy complete, I hit the ground running: I made cold call after cold call and delivered sample after sample. Some dispensaries were inviting, some rude, and others gave me the run-around. I stayed humble, with open ears, and true to myself, the brand and what I wanted to accomplish.

What's the first thing you had to do to start your cannabis business?

Well, regulations are constantly changing, so the first steps I took when I moved to Oregon was to research the requirements and file the appropriate paperwork with the state.

What are some skills you'd recommend for budding ganja-preneurs?

Always ensure a level of integrity and transparency in what you do. Protect your intellectual property, but don't shy away from speaking openly and honestly with other people—it increases confidence and promotes legitimacy. Customer service is everything, so try to be available as much as possible. Even if it's only one day a week, go check in or make a call and show that you care. And always be the face of your business—never delegate that! 🌿

SUNSET HYDROPONICS & HOME BREWING

come visit us at our new site!
sunsethydro.com

What are you waiting for? Let us help you get into the hydroponic, home brewing or wine making set-up that's right for you.

**FIND US ON THE WEB
OR VISIT ONE OF OUR
SIX LOCATIONS!**

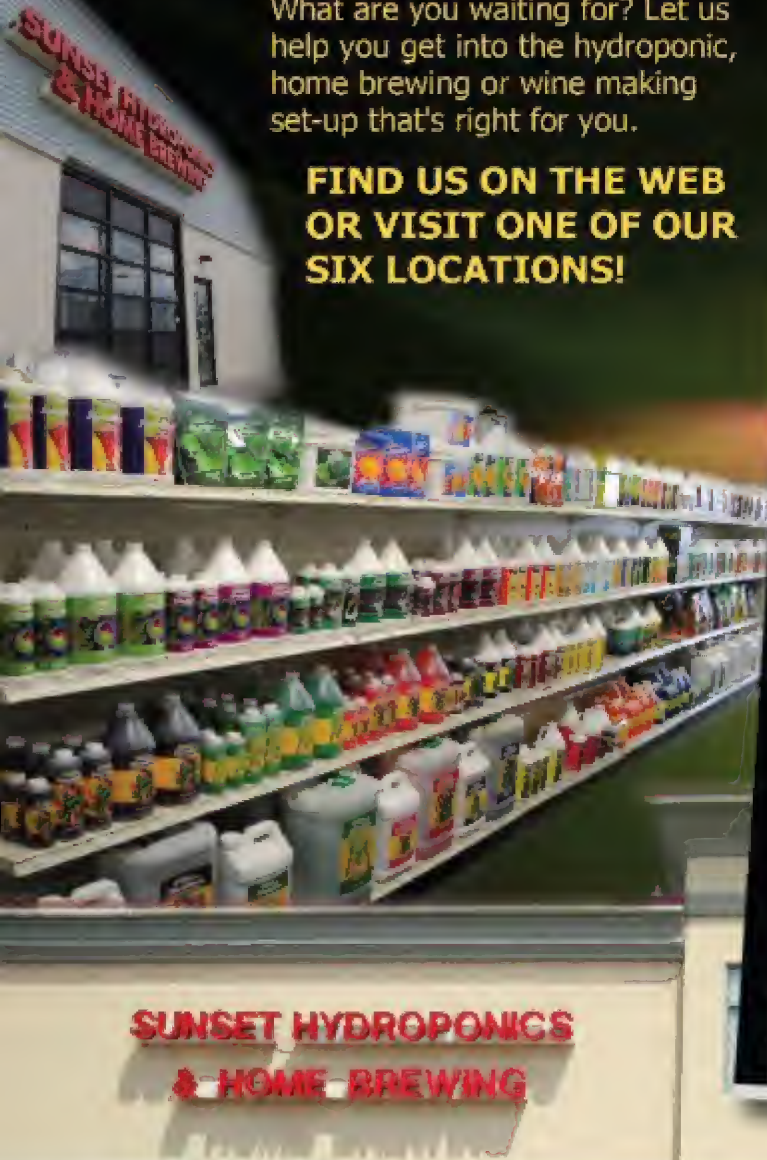

Toll-Free: 1-866-395-9204

TC Labs staffer Josh is joyous as he processes fresh extract.



From Clones to Concentrates

At TC Labs in Colorado, producing high-quality concentrates is the name of the game. *Story & Photos by Dan Skye*

Over the past two years, TC Labs has built its brand by working closely with Colorado's top cultivators, processing the very best plants into high-powered concentrates. The company has designed and constructed its own state-of-the-art "dab lab," including an expansive onsite grow op. Relying on a variety of genetic lines from star breeders like Mike and JJ-NYC of

Top Dawg, Tierra Rojo and Mendelian Dave of TR Seeds, and The Docta from Archive Seedbank, TC Labs painstakingly chooses each individual strain for its resin and terpenoid development, average concentrate yield, and general growth characteristics.

And the company has started to reap the rewards that this search for excellence has sown. TC Labs took home second place at the 2013 U.S. Cannabis Cup in Denver for Best

Medical Concentrate; it also shared first place at last year's Cannabis Cup in Amsterdam for Best Seed Company Concentrate, and grabbed top honors for Best Medical Concentrate at the recent U.S. Cannabis Cup in Denver.

TC Labs is now expanding its operations to provide high-quality concentrates to all legal and medical states. Here's a look at how these master extraction artists work their magic!

Visit tclabs.com or extractoutfitters.com.



(This page) The finest cannabis concentrates begin with the best cannabis—free of disease, pests and pesticide residuals, and cultivated to full maturity. TC Labs seeks out top-notch dispensaries that maintain these high standards and establishes working relationships with them. The choice of genetics will greatly determine the final product. Yield, effects, color and flavor all begin with the strains themselves and how well they're cultivated. In-house cultivators focus their attention on manipulating the grow environment, light spectrum and nutrient program to ensure that the strains are cultivated, harvested and cured to perfection.



The harvest and curing process can be the most difficult to master. Dry too quickly and it will spoil the aroma, leaving the bud smelling like hay. Dry too slowly and the buds can develop mold. TC Labs' drying rooms are split into separate areas with individualized climates, allowing the maintenance of proper humidity and temperature levels in this perpetual-harvest operation.



1. Once the bud has been dried and cured to perfection, lab technicians break down the plant material and begin packing it into the column of the facility's closed-loop unit. This column is capable of handling approximately 1,000 grams of plant material.

2. Once the column is hooked up to the unit and brought to pressure, the solvent is released, soaking the plant material inside. For TC Labs' purposes, this soaking process is kept to a minimum. The solution is then released into the collection basin of the unit and heated slowly; 80 percent of the solvent will be boiled off in this part of the extraction process. A pump is added to decrease run times and accelerate the recovery process.

3. Once the pump finishes recovery, the unit is disassembled. The solution is now scraped from the collection basin and placed on a tray.

THE INTERNET IS ABOUT TO GET A MILE HIGHER

BUY YOUR FAVORITE O.PENVAPE PRODUCTS, COMING SOON AT OPENVAPE.COM!



O.PENVAPE AND GO.PEN, A MATCH MADE IN DENVER. Use your O.PenVAPE pen with convenient pre-filled cartridges, and use your go.pen for your favorite waxes and extracts.



A FRIEND FOR LIFE
ALL O.PENVAPE
PRODUCTS COME WITH
A LIFETIME WARRANTY

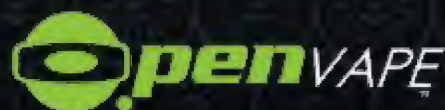

IT'S WHAT'S INSIDE THAT COUNTS

RETAILERS...INTERESTED IN CARRYING O.PENVAPE CARTRIDGES? CONTACT US AT ORDERS@OPENVAPE.COM



(Above and left) TC Labs uses laboratory vacuum ovens for the next step in the process. The oven introduces heat and pressure to remove the solvent left in the solution. The butane and hash solution will "boil" as the remaining solvent continues to release its bonds.



After several hours in the vacuum oven, the finished slab is cooled and then visually inspected by a quality-control technician.

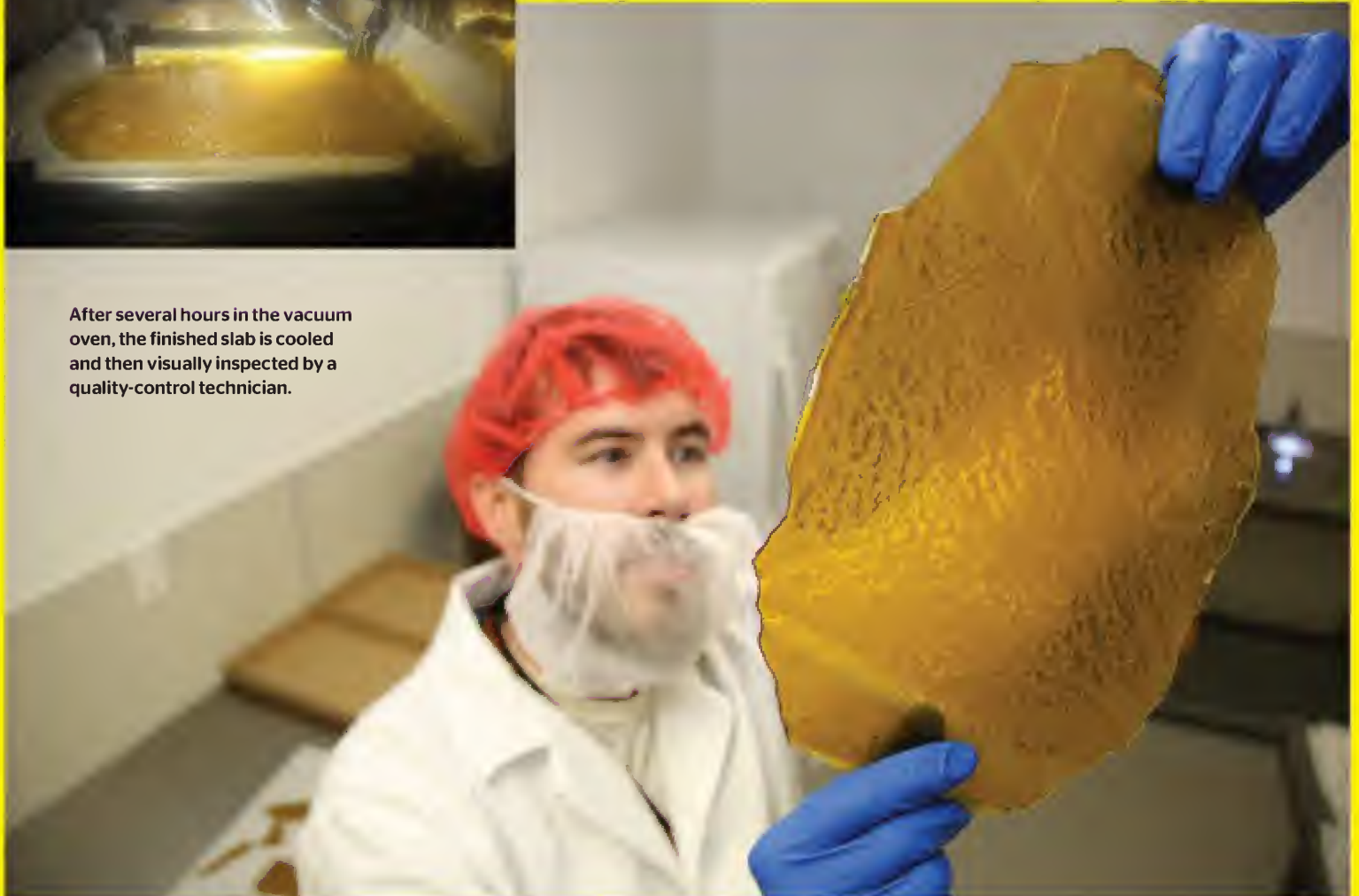

THE BUD-GETTING BONUSES YOU CAN'T BUY!

When you choose any of Advanced Nutrient's pH Perfect Base Nutrients, you will also receive 5 Bud-Getting Bonuses that are included in every bottle at no additional cost ... Other companies might charge hundreds of dollars for the same benefits these products bring you, but they're all included as part of the standard formulations in each of our cup winning, plant specific, base nutrients. They are ...



1. Wet Betty

Wet Betty is a non-ionic surfactant (also called a wetting agent) that lowers the surface tension of your nutrient-rich water allowing easier spreading and uptake of nutrients into your plants. That means your plants get the nutrients they crave faster and more efficiently than ever before. Plus, scientific testing by the leading plant PhD in surfactant studies shows **Wet Betty** (by itself) consistently increases plant growth by an average of 6%!

2. F1

Short-chain **Fulvic Acid** is still not 100% understood scientifically, but it directly stimulates plant growth and is 1,000 times smaller than humic acid — making it easily utilized by your plants. Fulvic Acid is also a natural chelator that gives you quicker nutrient absorption, transport, and enhanced cellular metabolism.

3. H2

Introducing long-chain **Humic Acid** to your root zone is like building a "condominium complex" for beneficial bacteria and fungi, giving them an optimal structure to flourish in.



4. Amino Acids

Many athletes supplement with **Amino Acids** to help fuel muscle growth because they're the essential "building blocks" of protein. In the same way, your plants benefit from amino acids! The broad spectrum of 20 amino acids in Advanced Nutrient's base nutrients fuel metabolic pathways for enhanced essential oil production and are essential to the construction of cell walls in stems, leaves, and flowers.

5. Balance-Free pH Perfect® Technology

When you use any Advanced Nutrient's base nutrient, the pH Perfect Technology inside automatically stabilizes and locks in your pH within the optimal range (called the "sweet spot") of pH 5.5–6.3 — and keeps it there for one week. No more pens. No more meters. No more being chained to your nutrient reservoir, checking and adjusting pH, because the scientific formulation does it for you. Plus, with a theoretical absorption range between pH 1 and pH 10 — this technology acts as a built-in safety net ensuring your plants can always lead even if some error or bad water source takes the pH above or below where it should be, you'll still be able to turn a good crop.

AGAIN, YOU CAN'T BUY THESE BUD-GETTING BONUSES — THEY'RE OUR GIFT TO GROWERS EVERYWHERE AND INCLUDED AT NO-COST IN EVERY BOTTLE OF ADVANCED NUTRIENTS PH PERFECT BASE NUTRIENTS!

To Find Out More Go Now To: AdvancedNutrients.com/5in1



Ask your local hydroponic retailer about what pH Perfect Base Nutrients can do for your garden today!



Advanced Nutrients
Revolutionizing Plant Potential

The slab is broken up into grams, then packaged and labeled. Should a client request budder, a technician will take a finished slab of shatter and place it on light heat, while whipping the product (inset) to the desired consistency.



STURDY-BUILT



Uni-Flow

BELL LIGHTING TECHNOLOGIES

WWW.WEST COAST GROWERS.COM
TOLL FREE 888 924-4769

CLOUD

HIGH TIMES MINI VAPE OF THE YEAR



USE CODE **HT420**
FOR **25%** OFF YOUR ORDER

SHOP NOW AT
CLOUDPENZ.COM



CLOUDPENZ



CLOUDPEN



CLOUDPENZ

ALL SYS GROW!

Everything you need to know about the best indoor setups.

Story & Photos by Nico Escondido



TEAMS

Before you head out to your local hydro shop, there are a few things to consider beyond just what type of grow system will fit in your available space. How does the system work exactly, and how much time and attention will it need? Are there moving parts that can break? Is there a lot of water involved that can flood a room or attract pests? And perhaps most importantly, what kind of medium will it require?

Here's a complete review of the most popular grow systems out there today, detailing how they work and what methods and mediums serve them best. So take a look at your space, pore over these pages, and then hop online or in your car to buy what you need to get up and growing quickly, easily and effectively!

Whether you're going big or just starting out with your own home grow, there's an ideal system for everyone.



A top-feed system with rooted plants in mineral wool cubes atop beds of soilless mix.

Passive vs. Active

To begin, we must first understand the differences between passive and active systems. As you might guess, a passive grow system is one that requires minimal maintenance. Passive systems have no moving parts such as pumps or spray emitters, since they rely solely on capillary action to move water from a reservoir to the medium. These setups are great for beginners because they use soil or, more typically, soilless mediums and require the grower to manually water and feed the plants, thereby keeping new growers in their gardens for longer periods of time—the very best way to learn about plants and horticulture.

Examples of passive grow systems include wick-system setups, standard window boxes or simple gardens using potted containers. These types of systems are recommended for first-time growers, even if you have grander designs later on. Plants can be finicky, and before you spend loads of money on expensive equipment, it's best to learn on the cheap.

For the intermediate to advanced grower, active grow systems can be a lot of fun as well as extremely rewarding, both in terms of quality and yield. Active systems encompass almost all of the other grow systems available on the market. These deliver water and nutrient solution to the medium and root zone

using moving parts and energy. Cannabis grows quickly, which makes it an ideal match for active hydroponic systems.

Hydro vs. Non-Hydro

To break it down even further, active grow systems can be divided into two categories: hydroponic and non-hydroponic systems.

Strictly speaking, hydroponics is the cultivation of plants without using soil. However, these days very few indoor growers actually use soil. Instead, they prefer a soilless mix that is most often composed of a peat or sphagnum moss base. These mixes have a look and feel very similar to regular topsoil, but they usually have a few other additives mixed in (more on this later).

New growers sometimes think that using soilless mixes means that the grow system cannot be hydroponic—but, technically speaking, as long as the system doesn't utilize actual earth soil, the system is classified as hydroponic. The only true non-hydroponic systems in use these days are outdoor or greenhouse gardens, and even then many growers use a soilless mix, as these mediums are usually sterile and come pest- and disease-free. Some of these mixes even have mild organic nutrients added to the medium, giving them an edge over conventional soils.

About Soilless Grow Mediums

When choosing a soilless medium, it's important to read the ingredients label carefully and have a good idea about what you desire beforehand. Most soilless grow mediums are mixtures of the following components:

Peat. One of the most popular soilless-mix bases, peat is the partially decomposed remains of vegetation and flora that have been preserved underwater or in a semi-aquatic state. Its look, feel and texture are similar to fine earth soils, and it is heavily loaded with organic minerals. There are three types of peat: peat moss, peat humus and reed sedge, with the first two being the more popular commercial forms.

Sphagnum moss. Sphagnum moss (or sphagnum peat, as it's also called) is the dehydrated residue or living portions of bog plants; it falls in the plant classification system under the genus *Sphagnum*. It's usually pathogen-free, always light in weight, and has an extremely high capacity for water retention. Sphagnum is more desirable as a grow substrate than standard peat; however, its high cost has limited its commercial use.

Coco coir. If peat is the most popular choice as a soilless-mix base, then coco coir is a very close second. It's an extremely adaptable substrate that can serve many functions. When ground to a finer consistency, coco coir makes an excellent base for soilless mixes, and when shredded into fibers or chunked into small croutons, it can serve as a great additive to peat-based mixtures, as these forms help aerate the medium. In any form, coco coir—which is made from coconut husks—is highly absorbent and can retain moisture while holding its form for long periods of time.

Vermiculite. Vermiculite is an aluminum silicate mineral common in igneous and metamorphic rocks. Mined heavily in both the United States and Africa, vermiculite expands noticeably when heated, making it lightweight and insoluble in water. Mostly used as an additive for soilless mixes, vermiculite is neutral in reactions and offers excellent buffering to the root zone while also holding moisture and nutrients very well due to its high cation exchange capacity (CEC). This makes it one of the best soilless additives available.

Advanced Grow Tip: The term "peat-lite" refers to peat-based mediums that contain perlite or vermiculite.

THE TRIMPRO FAMILY OF PLANT TRIMMERS CHOOSING YOUR TRIMPRO

FOR VERTICAL OR HANG DRYING

Choose from two MANUAL CONTROL units the model best suited to your capacity and working environment needs.

MANUAL CONTROL UNITS

TRIMPRO TRIMBOX

TRIMPRO ORIGINAL



FOR HORIZONTAL OR RACK DRYING

Select from these exceptional models, ranging from our small, power-free ROBOTIC TOUCH unit, to our medium and high production MANUAL CONTROL and AIRFLOW units.

MANUAL CONTROL UNITS

TRIMPRO TRIMBOX WORKSTATION

TRIMPRO ORIGINAL WORKSTATION



ROBOTIC TOUCH UNITS

TRIMPRO UNPLUGGED

TRIMPRO ROTOR

TRIMPRO ROTOR XL

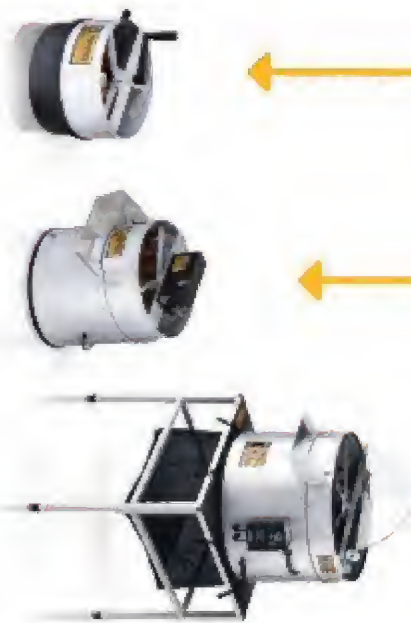

AIRFLOW UNITS

TRIMPRO AUTOMATIK

TRIMPRO AUTOMATIK XL

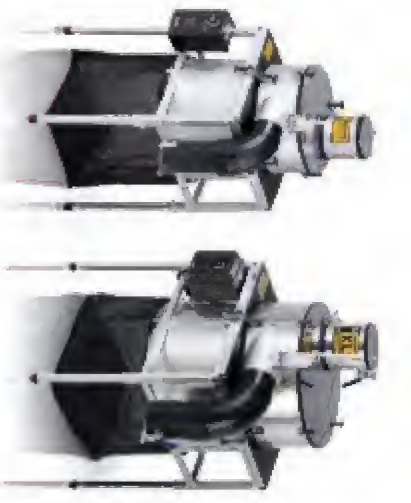

TOLL FREE 1-844-TRIMPRO



UNRIVALLED INNOVATION

INFO@TRIMPRO.COM TEL.: +1 450 349-0811 1-844-874-6776
 PATENTS: CANADA: 2,470,370 USA: 7,188,643 EUROPE: 1,662,859 01 AUSTRALIA: 2004289786 CSA AND CE STANDARD



TRIMPRO.COM

Types of Hydroponic Systems

There are quite a few commercial hydroponic systems out there today, available in grow shops and online. Some of them come as turnkey solutions for indoor growrooms, while others are scalable and customizable depending on your needs. The turnkey models generally include flood-and-drain or deep-water culture (DWC) units. The latter are used more by intermediate to advanced growers and usually include top-feed setups that allow for a range of mediums and plant sizes.

Let's start by taking a look at some of the easier-to-use beginner systems and then work our way into the more customizable aspects of indoor grow systems.

Ebb-and-Flow

These systems are among the most popular with first-time hydro growers and use a simple formula for garnering larger yields and potent plants: lots of water and lots of oxygen to the root zone. Of course, this doesn't happen simultaneously. In fact, these hydro systems keep the plants' roots in the open air most of the time—but when the water comes, it comes heavy.

Also known as flood-and-drain, these setups use flood tables, reservoirs, and pumps to feed plants water and nutrient solution and require mediums that can retain moisture for long periods of time. Pumps on timers flood the tables for short cycles and then drain the solution back into the reservoir (although some growers choose to drain the solution to waste and do not recycle it). The most popular grow mediums used in ebb-and-flow systems are rockwool and HEC (hardened expanded clay). Each one has its pros and cons, but for beginners, the choice is most often rockwool because it's easier to start seeds or clones in these plugs and then transplant them into larger cubes or slabs. The one big drawback here is that rockwool offers little help to beginners in the way of buffering for young plant roots as they adjust to harsher nutrient programs.

Advanced Grow Tip: An easy workaround in this regard is to start seeds or clones in peat plugs and then transplant them into netted pots filled with HEC. However, HEC may not hold moisture long enough for new plants, and thus more frequent waterings are required, which in turn necessitates more attention from growers. Another option is to create an HEC/rockwool crouton mix in which to nestle the starter plugs.



Deep-water culture (DWC) systems like this one can be easily tailored to fit any space.



Aeroponic cloners like this one are great for accelerated root growth.

Deep-Water Culture

Deep-water culture setups are great for beginners and more advanced growers as well. DWC—also known as “bucket systems” or “hydro pots”—utilizes large buckets or containers, with netted pots sitting in a hole in the top so that the roots hang down into the container. These buckets are linked to a single reservoir, with the size of the reservoir ultimately determining how many plant containers can be linked together.

The system works by pumping water or nutrient-rich solution from the reservoir through irrigation lines to the base of each plant site. The plant containers then fill with water from the bottom up, saturating the roots. After a few minutes, the containers drain and recycle the water or solution back to the reservoir, with short-cycle timers repeating the process several times a day. Other DWC systems allow the water to sit until it's completely wicked up by the plants' roots and then refill the buckets using float valves as the trigger.

Advanced Grow Tip: There are quite a few different DWC systems, and most can easily be modified by intermediate-level growers. These systems will produce large, bushy plants, but they require a lot of attention and plenty of lighting.

NFT and Aeroponics

NFT (nutrient-film technique) and aeroponic systems are similar in that they both require the plants' root zones to be completely enclosed in order to achieve the best results. For beginning growers, this can be a problem, as access to the root zone is important in identifying early problems within a garden. Additionally, there are a lot of moving parts in both systems that require time and attention.

NFT systems generally utilize a conduit in which the plant containers sit with the roots hanging out. Netted pots or basket containers are often used here. The roots grow down into the conduit, usually large-diameter piping or a rectangular trough. A thin film of nutrient solution is then pumped in and passes along the bottom of the root zone as the dangling roots wick up water and minerals.

Aeroponic systems work in much the same way—however, instead of a thin nutrient film passing through a conduit, these systems utilize sprayer heads that periodically emit a fine mist to the root zone. This mist is caught by the fine hairs of the roots, and the nutrients get absorbed easily.

Both NFT and aeroponic systems can achieve large yields and high-quality flowers, but they can also be difficult to manage, as they offer little to no buffering for delicate root systems. Getting the NFT solution to the proper flow levels in the conduit, or ensuring that all spray emitters (and the spaghetti lines feeding them) have the proper pressure in aeroponic systems, can be challenging for first-time growers.



NEXUS
DISTRIBUTION CO.

**BEST IN
GLASS**



NEXUSGLASS710



NEXUSGLASS710@GMAIL.COM

Types of Hydroponic Grow Mediums

Rockwool. Rockwool (or mineral wool) is produced from various mineral sources. Once superheated, it is spun into fibers and then pressed into cubes or slabs as it cools. Mineral wool is used both for rooting, such as in rockwool plugs or small cubes, and as a grow medium in the form of larger slabs or crouton beds. Rockwool is sterile and inert and can be used in all kinds of mixtures or as a stand-alone substrate. The primary benefit of rockwool is that it retains substantial amounts of H₂O while also allowing ample air to penetrate the root zone. One major drawback is that rockwool is not a forgiving medium, offering the least amount of buffering for roots than almost any other option (the only exception being HEC). Growers using rockwool need to know their nutrient programs and strains very well.

HEC (hardened expanded clay). When heated, HEC can produce a tough and stable substrate that is porous and capable of absorbing decent amounts of water. However, like rockwool, HEC offers no nutritional value. Both HEC and rockwool can be difficult to master because they require the grower to intimately understand nutrients and ppm levels within the solutions for feeding. That being said, HEC is a great medium for use in heavy-watering hydroponic systems. The clay substrate is weighty enough to keep peat or rockwool plugs with rooted seedlings or clones in place during heavy water flows, and it also allows for easy drainage and extra aeration. Remember, roots breathe in oxygen, so airflow in the root zone is integral to healthy plant development.

Perlite. Although perlite is mainly an additive, some advanced indoor growers will go with levels in excess of 50 percent when adding it to their peat- or coco-based mixes. Perlite is a gray-white volcanic medium, usually mined from hardened lava flows. The crude ore is crushed and screened, then heated in furnaces to over 1,400°F, which expands the particles to small, sponge-like kernels that are lightweight and highly moisture-absorbent—their key feature.



Seedlings in soilless mix.

Advanced Grow Tip: Creating custom blends using 50 percent perlite added to peat or coco bases is an excellent way

to dial in indoor grow operations and match your strain to your medium. Cover the entire surface of any peat- or coco-based medium with perlite to help lock moisture in.



Soiless Grows

As discussed earlier, soilless grow systems are still technically considered hydroponic because they use non-soil substrates as the primary medium. However, these grow systems do not conform to the general notion of hydroponics these days, as many of the standard hydro systems available are not a good fit with soilless mixes. For example, a grower who attempts to use a peat-based soilless mix as the medium in an ebb-and-flow system will find that it creates quite a mess, with the loose medium dislodging from the root-ball and being carried out of the plant containers to block drains, dirty reservoirs, and clog pumps and feed lines. In this type of setup, a more stable medium is required.

This is where top-feed systems come into play. These are currently among the most popular methods of indoor cultivation, as there are a variety of models that can be deployed and a variety of mediums that can be used in these setups. Let's take a closer look at how these grow systems function.

Top-Feed Drip

Of the three types of top-feed systems outlined here, the drip system generally provides the most constant flow of water and/or nutrient solution to the plants. In these systems, the plants are best placed in individual containers so as to ensure that each one gets enough water and nutrients. These systems often use flood trays to catch runoff, which can either drain to waste or circulate back to the main reservoir.

From the reservoir, water is pumped through main lines up to the tables, where smaller irrigation or spaghetti lines feed the individual plant sites. Stakes are used to hold lines near the base of plants, and drip emitters at the end of the lines slowly drip water into the medium. Some growers choose to have a constant drip going during the "daylight" portion of the photoperiod, while others use timers to trigger drip cycles.

Advanced Grow Tip: Using a solid medium such as soilless mixes or larger rockwool slabs aids in staking drip emitters to the plant sites.

From top: Rockwool cubes on top of rockwool slabs in a top-feed system; hardened expanded clay (HEC) being used in an ebb-and-flow hydro system; young clones inserted into fabric bags of a coco-perlite medium.



Rocky
Mountain  **HIGH**
Dispensaries
COLORADO

Now Serving
21+

WWW.RockyMountainHigh.CO

ROOT MASS EXPANDERS

TRIBE

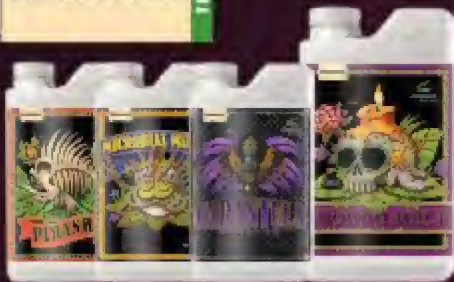

EXPAND YOUR ROOT MASS 700% TO 1,000%! IT IS A KNOW SCIENCE FACT: BIGGER ROOTS PRODUCE BIGGER YIELDS.

Voodoo Juice - Expand root mass by up to 117% and increase nutrient absorption by up to 700%! Watch your plants suck up energy and nutrients like crazy for vigorous growth - and ultimately bigger yields.

Piranha Liquid - Expand the surface area of your plant roots by up to 75%. Helps your crops obtain as much as 86% more nitrogen, 234% more phosphorous, and 75% more potassium. This means heightened vegetative growth, greater leaf area, more bud production, better flower structure, and increased weight. Piranha Liquid also seeks and destroys harmful pathogens and molds, while strengthening crop resistance to stress.

Tarantula Liquid - Its beneficial bacteria inoculate the roots, safeguarding them by competing with and warding off harmful bacteria that can infect your plants. Reduces tissue damage from heavy fertilizer salts. Increases plant growth and yields by releasing growth and bloom co-factors and aiding chlorophyll, so your high-intensity lighting is more effective.

Microbial Munch Coming SOON - Maximize your microbes! Support, strengthen and maximize the benefits from all the beneficial microbes and fungi. It's a "superfood" - exactly what your plants need to transform into bigger, stronger, more resilient and more beneficial creatures. In short, it's like putting them on steroids.

BUD POTENCY & STALK STRENGTHENER

TRIBE

GROW MORE GLISTENING, STICKY, RESIN-GLAZED, TRICHOME COVERED BUDS AND STURDIER, STRONGER, STALKS AND BRANCHES!

Rhino Skin - Increases trichomes and essential oils for more potent harvests. Your crops will stand up straighter and support bulkier, heavier buds. You'll get big, sticky, potent harvests with greater market value.

Bud Factor X - Triggers systemic acquired resistance (SAR) within plants to produce markedly higher amounts of essential oils and terpenoids, which directly benefit taste, aroma, and resin production, giving you higher quality crops with greater market value.

Nirvana - Guarantees bigger yields and bigger, denser, heavier buds... while driving your plants at a faster metabolic rate. Experience increased yield, quality, aroma, color, essential oils, and resin production faster than you could have imagined without using synthetic nutrients.

B-52 - Amplifies overall plant metabolism, promotes strong root development, boosts growth and helps your crops fight off stresses such as intense light, cold weather, ozone, drought and salinity.



BUD AID

TRIBE

"INSURANCE" FOR YOUR GROW ROOM

Sensi Cal Mag Plus - If you're using base nutrients made by other companies, your crops could be deficient, leading to stunted growth and yellowing leaves. You can prevent that with Sensi Cal-Mag Plus, the only calcium and magnesium supplement formulated with the exact Ca, Mg, and Fe ratios unique to the high-value plants we grow.

Revive - Guaranteed to rejuvenate your crops if they get into nutrient-deficiency trouble - which can happen if something unexpected and beyond your control occurs... or you're using inferior nutrients. Save in distress plants by adding it to your nutrient solution or using it as a foliar spray at the first sign of trouble. These rejuvenating substances flood the plant with healing nutrition. Use it at the first sign of trouble and your precious plants will get their best chance not only to survive, but thrive!

CROP SUBSTRATE SUPERCHARGER

TRIBE

THE MOST OVERLOOKED AREA FOR GETTING POUNDS OF BUDS

Ancient Earth Organic - A rich combination of humic and fulvic acid that will help transform your growing medium into a richer, healthier, more vibrant foundation for your crops while pumping up their roots. Also stabilizes the pH and optimizes nutrient delivery. Helps plants withstand disease, drought and other environmental stresses.

Sensizym - Specifically formulated enzymes that scour the root zone, removing debris and eradicating disease by "recycling" it into usable carbohydrates that fuel bud growth and boost yields. Growers report it also decomposes root zone debris so well, you can often reuse growing media such as rockwool and coco coir for another crop lifecycle - saving you money!

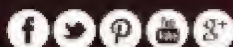

Ask your local hydroponic retailer about what Advanced Nutrients can do for your garden today!

WELCOME TO THE TRIBE!

ANY ONE OF
ADVANCED
NUTRIENTS
CANNABIS
ENHANCERS
WILL PACK
SIZE, DENSITY
AND WEIGHT
ON YOUR BUDS
AND HELP YOU
ACHIEVE THE YIELDS
YOU'VE ALWAYS
IMAGINED.
AND WHEN USED
TOGETHER WILL
GREATLY ENHANCE EACH
OTHER'S EFFECTIVENESS.



BIGGER BUDS

OPTIMIZES YOUR 3 CRITICAL PHASES OF BUD DEVELOPMENT!

Bud Initiation Phase

Bud Ignitor - All the energy your high-value crops had been putting into vegetative growth will transfer into a massive burst of blooms. You'll start to see signs of prolific budding within 5 days, instead of 10 or more without it.

Mid Flowering Phase

Big Bud Liquid - The Initiations Phase - In the same way bodybuilders take in amino acids after a workout to bulk up on proteins - the building blocks of life - so too do your buds need a big amino boost. See gains in size, mass, and potency from the rich assortment of bio-available, amino acids.

Ripening Phase

Overdrive - Get even more out of your plants during the finishing phase. Reinvigorate your crops with a second wind, giving you much bigger yields when harvest day dawns.

Start Putting The Tribes To Work For You Today ...
Go Now To AdvancedNutrients.com/Tribes

 **Advanced Nutrients**
Revolutionizing Plant Potential

BUD TASTE &
TERPENE ENHANCER

TRIBE



THE "SECRET" TO MAXIMIZING TASTE, INTENSIFYING FLAVOR AND AMPLIFYING THE AROMA OF YOUR CROPS

Bud Candy - The simple and complex carbohydrates in Bud Candy give them an instantly accessible source of energy for more floral growth. Includes bloom-enhancing plant extracts that increase essential oils for higher potency, better aroma, richer flavor and deeper, more pleasing colors.

Flawless Finish - Removes excess chemical residues from your growing medium, pots and other plant tissues, including fruits and flowers. You'll have the cleanest, sweetest yields possible. Use Flawless Finish right before your next harvest and taste the results for yourself.



Tabletop irrigation system for top-feed hydroponics.



A spray-emitter system.

Top-Feed Timed Flow

These systems are almost identical to drip-emitter systems but rely on a timer to deliver a periodic flow of water from the reservoir to the plant site. This option can be useful in large, commercial-format grow operations with hundreds of plants, or in setups where the grower prefers to have only one emitter at each plant site. In this system, a nozzle or emitter isn't necessary, as open-ended irrigation lines can be simply staked into the medium ready to flow.

Depending on the medium, growers can choose various lengths for each watering period and use short-cycle timers to generate several feedings per day.

Top-Feed Spray Emitter

Spray emitters are the most popular top-feed system out there today. Many growers prefer the specialized sprayer heads over a drip-emitter system because they provide a more even watering throughout the entire medium at each plant site. In all top-feed systems, growers generally use two to four emitters per plant site, but when four spray nozzles are staked around one plant base, very even

saturation can be achieved.

The only pitfall with this system is that it's not ideal for some nutrient programs, especially synthetic nutrients that are heavy in salts. This is simply because salts build up quickly in thin irrigation lines and often clog spray emitters, which rely on tiny holes in the nozzle heads to create pressure and an even distribution of nutrient solution.

Advanced Grow Tip: Most advanced growers use top-feed systems with soil-less mixes as their medium. However, it is often recommended that you measure the saturation point of your medium and then set your short-cycle timers to match that duration and then shut off. Next, measure the amount of time it takes for the medium to dry out, then add 15 minutes and set that period as the interval between watering cycles. 🌱

ACQUISITION OF LIVE CANNABIS SEEDS IS ILLEGAL IN THE UNITED STATES | PAYABLE IN US DOLLARS FROM ANYWHERE IN THE WORLD.

MTG Seeds
Grow *BIG*... or grow home!

COSMIC CHARLIE
GODFATHER KUSH
TURBO DIESEL
PINA COLLISION
PREZIDENTIAL KUSH
STONEY CREEK OG

AND MORE AWARD WINNING STRAINS AVAILABLE AT MTGSEEDS.COM

Afghani x Skunk #1







HIGH TIMES
PURPLE TRAINWRECK

Fire of Puhnja





GROW GREENTM with G8LEDTM Technology

Full Spectrum LED Grow Lights

Optimal 8-BandTM Ratio for Healthy Growth and Maximum Yield

G8-900 Veg / Flower



Coverage 24+ Sq. Feet
110 / 240V - 4.4/2.0Amp
288 x 3W Diodes

\$1099

G8-90RR Red



Flower Booster

\$149

call for catalog

888-771-GROW

G8-600 Veg / Flower



Coverage 18+ Sq. Feet
110 / 240V - 3.3/1.6Amp
200 x 3W Diodes

\$899

G8-450 Veg / Flower



Coverage 12+ Sq. Feet
110 / 240V - 2.2/1.0Amp
144 x 3W Diodes

\$599

G8-240 Veg / Flower



Coverage 6+ Sq. Feet
110 / 240V - 1.2/0.7Amp
80 x 3W Diodes

\$309

G8LEDTM indoor growing technology is formulated as a high performance and highly efficient growing system. Through several iterations of growing and testing, G8LEDTM designed the Optimal 8-BandTM ratio with the weighted average of the exact spectra needed for indoor growing without any waste. The Optimal 8-BandTM ratio provides the energy source from seedling to cloning to flowering, giving plants healthy growth and prolific flowering for maximum yield per watt. Dorm Grow LED is the main distributor of G8LEDTM Lighting Company. We pride ourselves on Quality and Customer Service. We ship worldwide to over 130 countries and territories. Privacy is of the utmost importance to us. We protect customer information in our SSL secure and encrypted database. We will never share customer information with any outside sources or for any commercial purposes. We guard your information as part of our service to you to build a long lasting relationship with our customer base. We welcome the opportunity to earn your trust and deliver you the best service in the industry.

Grow Green with G8LEDTM Technology!

Optimal 8-BandTM with UV & IR

available at
www.DormGrow.com



MOUNTAIN MEDICINE

TWO TIME HIGH TIMES CANNABIS CUP WINNER

WWW.MTNMEDS.COM

Get your goat on.

\$30 RECREATIONAL 1/8THS

330 E. Colfax Ave
Denver, Colorado 80203



Good Chemistry

MEDICAL + RECREATIONAL. 21+

HOME OF \$30 RECREATIONAL 1/8THS

330 E. Colfax Ave
www.goodchem.org Denver, Colorado 80203 T. 720 524 4657



Genius, inventor and
psychedelic wizard
Alexander Shulgin.

The Last Alchemist

Alexander “Sasha” Shulgin, perhaps the greatest psychedelic research chemist of all time, passed away on June 2, 2014, just 15 days before his 89th birthday. Unaware of his dire health, *High Times* had paid a visit to his laboratory the previous week. Though obviously ill, Sasha exhibited his trademark humor, asking why we had come so far to visit. When one looks at his life and achievements, the answer to that question is clear. *By James Kent*

East of Oakland, and overlooking Mount Diablo, a hobbit-hole has been dug into the side of Pleasant Hill. It’s a modest structure, gilded with a patina of rust and rot, swallowed by years of English ivy. But inside this humble cottage, a great White Wizard has crafted his alchemical hideaway. On most evenings, the Wizard could be found there hunched over bubblers and boilers, listening to string quartets, condensing spirits from aromatic wisps and vapors, occasionally releasing a plume of steam and stench. Around him was a cathedral of colored jars, bottles, flasks and vials, each one holding a potion or powder of unimaginable power, labeled with glyphs that only another alchemist could decipher. A bottle of sweet-smelling oil might be a deadly poison or a powerful aphrodisiac; a jar of white powder could be a miracle cure or a pinch of the philosopher’s stone.

This place may sound plucked from fantasy, but I can assure you that it’s real. It’s the laboratory of the famed psychedelic chemist Alexander Shulgin, only thirty minutes from Oakland in Lafayette, CA. Of course, this wizard was more likely to be found in ethnic print shirts than white robes, and the string quartets came from the tinny speaker of a beat-up transistor radio via the local public radio station. But other than a few artifacts of the modern age, this alchemical hideaway could have been the timeless lair of any 17th-level magic user worth his salt. And in this laboratory, Alexander Shulgin designed, synthesized or discovered more psychedelic and psychoactive molecules than any other chemist who’s ever lived.

Standing in Shulgin’s lab just days before his death, I am struck by a sense that Alexander—“Sasha” to his friends and family—may be the last of his kind. At 88 years old, Sasha Shulgin is the last of America’s gentlemen scientists—self-employed innovators in the mold of Einstein or Tesla. These were educated men with the personal means to pursue the science of discovery purely out of interest. Shulgin was unconstrained by corporations or academic institutions demanding results. Free to follow his passion, he was arguably the most prolific psychoactive chemist of the 20th century, producing hundreds of novel psychedelic compounds during the course of his career. Looking over the rows of jars with faded and yellowing labels, I can only wonder how long each bottle has been sitting there. Some hold substances synthesized last year; others were forgotten four decades ago, added to Shulgin’s ever-growing list of projects put on the back burner. But now his days of working in the laboratory are finally over. The bubblers and boilers sit cold and dry; the inscrutable glyphs stare silently across a maze of tubing and glassware.

Legend has it that the Wizard retired to this alchemical hideaway in the late ’60s, but the story starts long before then. Even as a child, Shulgin was a prodigy. Both of his parents were teachers, musicians and prolific poets, but even in a family like that, Sasha was a bit of an oddball. “He had to learn how to tone it down—you know, to be funny and engage people,” says Ann Shulgin, Sasha’s second wife and collaborator of over 30 years. “He knew that if he appeared too smart in front of the other children, he wouldn’t be accepted ... he would be the boy that no one liked.”

But the child prodigy who hid behind playground fart jokes had an organic chemistry textbook in his backpack that he'd memorized by the age of 11. He attended Harvard University on a scholarship at the age of 15, then dropped out to join the Navy in the middle of World War II. "He always said he was 'hypo-maniac'—just a little below fully manic," Ann Shulgin recalls. "So he needed to have all these different projects and new experiences to keep his mind occupied." To relax, Sasha would play the viola or piano, often dropping into Prokofiev's *Peter and the Wolf* to lighten his mood.

After his stint in the Navy, Shulgin finished his PhD at the University of California at Berkeley and eventually landed a senior research position at Dow Chemical. His commercial success with the biodegradable pesticide Zectran won him the freedom to study whatever he chose while at Dow. Shulgin's primary interest was in psychoactive drugs—particularly mescaline, to which he'd been exposed in the late 1950s. He was also intrigued by the rumor that prison inmates were using nutmeg as a psychedelic drug and wanted to identify the psychoactive component in the spice.

"You have to remember, back then there was a great deal of hope that figuring out these psychedelic molecules would be the key to solving all kinds of mood disorders—insanity, schizophrenia, psychosis, dementia, the whole lot," says Paul Daley, Shulgin's longtime collaborator and heir apparent. "Of course, we now know it's not quite that simple—but the laws changed shortly after that, and most of the research just ended."

As the legal mood toward psychedelics shifted in the early 1960s, Shulgin left his position at Dow and retired to spend time with his family. The Wizard's beard grew longer and whiter. He played his viola with local string quartets—"because quartets always need a viola," Ann explains. "It's an easier position to fill." And on one of those days, he cleared out the old hobbit-hole, a brick-walled basement left over from a building that had burned down long ago. It was full of spiders and rat droppings, but Sasha had a vision: This would be his laboratory. So he began collecting equipment. "He was a scrap hound," says Daley. "He would collect whatever equipment he could get his hands on. Anytime a local chemical company went out of business or was throwing something out, he'd be in the truck. He would take almost anything—glassware, chemicals, solvents, propane, precursors ... he would take it all."

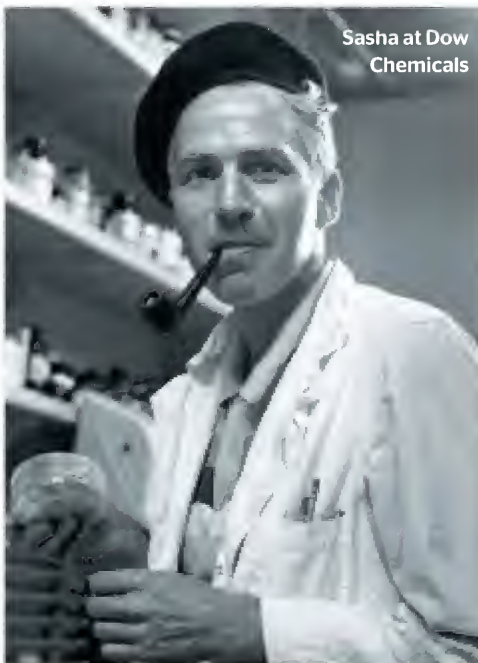

Shulgin's primary interest was in psychoactive drugs—particularly mescaline, to which he'd been exposed in the late 1950s.

Piece by piece, the alchemical hide-away came together, and then the Wizard went to work. Late at night, the old radio played symphonies as Sasha conducted with a glass stirring rod, checking temperatures in reaction vessels, evaporating droplets of colored liquid into clear dishes of oils, waxes or salts. Then, once a pinch of the newly created substance was properly washed and dried, into a little brown bottle it went. A simple but arcane schematic of the molecule was scrawled on a label and taped to the front. These little drawings became known as Sasha's "dirty pictures." And whenever a new molecule appeared, it was tested—first on Shulgin himself, in small doses, and then on a trusted group of researchers and friends. The results were sometimes disappointing; other times, they were spectacular.

Because of his friendly advisor's relationship with the DEA, Shulgin was able to obtain a Schedule I research license that allowed him to synthesize, possess, and test new psychoactive drugs on himself and others. It is impossible to overstate how much of a pioneer Shulgin was in this field. Says Kenneth Morrow, the founder of Trichome Technologies and an expert on cannabis extractions: "There are dozens of active and inactive compounds in cannabis—terpenes, cannabinoids and so on. We take all this stuff for granted today, but Shulgin wrote the first paper on

this back in 1971." (For the record: Shulgin, A., "Recent Developments in Cannabis Chemistry," *Journal of Psychedelic Drugs*, Vol. II, No. 1, 1971.) Back in those days, there was a grove of pot plants in the Wizard's backyard. The federal government had issued Shulgin marijuana tax stamps so he could legally grow cannabis for research purposes. "Today, the cannabis market is obsessed with isolating cannabinoids for medical purposes," Morrow observes. "And here Shulgin was, doing this research 40 years ago!"

Sasha and Ann often experimented with psychedelics together and shared their findings with their confidential research group. "Different people have different body types, so Sasha thought it was important to see how a drug reacts in all kinds of people." When I ask Ann about his favorite among all the chemical compounds he'd created, she answers immediately: "It would have to be 2C-B. He was always very proud of that one. He called it the 'Great Teacher' ... although I preferred 2C-B-FLY a bit more."

But there are so many to choose from: DiPT, 5-MeO-AMT, 5-MeO-DALT, methy-lone, 2C-T-7—the list goes on and on. Ann can't say for sure how many trips they shared together; she just smiles and admits, "We stopped counting at around 2,000." This is a mind-boggling number—except when you consider that the total may actually be closer to 4,000.

When pressed to reveal elements of Sasha's darker side or other experiences that were frustrating, Ann pauses and thinks. "He was not a perfect man," she says at last. "He could get moody and stop talking ... the communication would stop." I ask for an example. "Well, you could tell Sasha was in a bad mood if he was cleaning something. If you saw him in the kitchen washing the dishes, you could be sure there was something really bothering him, and you'd better stay out of his way."

Paul Daley confirms that Sasha was the same in the lab. "If he ever hit a sticking point or couldn't figure out why something wasn't working, he would begin breaking down the lab and cleaning things. He'd clean the glassware, the tubing—scrub it all out. And by the time he was done cleaning and setting up, he'd have thought of two or three more things to try ... or 11."

Although Shulgin worked with many types of drugs, his favorites were the phenethylamines, psychedelics that are more thoughtful than overpowering. Ann recalls a time that she and Sasha tried the psychedelic brew known as

THE MEDICAL **EARL**
TWIN COIL VAPOR PEN

RETAIL PRICE \$89.99



www.MEDICALISTORE.COM
SALES@MEDICALISTORE.COM



Easy Butter

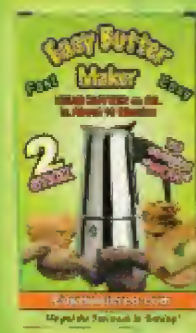

1 Stick Unit
\$39.99

2 Stick Unit
\$49.99

Maker

HERB BUTTER OR OIL
In About 10 Minutes

MEDICAL, RECREATIONAL AND THERAPEUTIC NEEDS
No Electrical or Moving Parts to Fail



Easybutterco.com



Find other great products on our site

QUALITY PRODUCTS WITH FAST DELIVERY. • CLIFTON, CO 81520 • HOURS: 8:00 - 5:00

970-644-6115

ayahuasca with their local circle. “Sasha had a hard time with that one,” she says. “I don’t think he liked all the different stuff going on, and it just didn’t agree with him.” Whether it was the constraints imposed by the ritual, the bitterness of the tea, the nausea and heavy hallucinations, or all of that combined, Ann says ayahuasca wasn’t for them. “We tried to finish the ritual, which required taking a second dose—so we took a smaller dose and tried to ride it out.” Ann remembers very clearly that it did not go well. “Sasha’d had enough by that point, and later in that trip I heard a spirit or a voice in my head telling me, ‘Don’t come here again.’”

Shulgin’s golden era of unfettered psychedelic exploration continued for more than two decades, his discovery of new chemicals eventually reaching into the hundreds. “He was very proud of his Schedule I DEA research license,” Daley recalls. “It was the first thing he showed me when I arrived at the lab in 1977. It was pinned to the wall right inside the door. He just pointed at it and smiled.” That little golden ticket gave the Wizard the power to work his magic without interference.

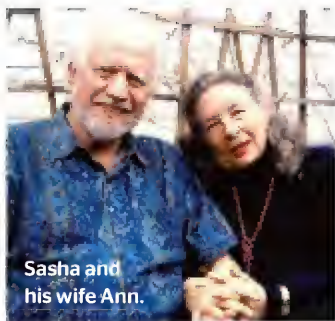

Sasha and his wife Ann.

Shulgin had always had a good relationship with the DEA. He was one of their experts—in fact, he was *the* expert; he even taught seminars and wrote law-enforcement reference documents.

But his relationship with the Feds changed in 1991 after he wrote *PiHKAL* (short for *Phenethylamines I Have Known and Loved*), a “chemical love story” and large-scale reference work that chronicled his discoveries in the phenethylamine family, including his star creation, 2C-B. The psychedelic community saw *PiHKAL* as a groundbreaking work of immense importance; the law-enforcement community viewed it as a cookbook. Shulgin was no longer the DEA’s expert; now he was everybody’s expert. The Feds definitely didn’t like that.

The DEA finally decided to revoke Shulgin’s Schedule I license in 1995 and raid his alchemical hideaway, an event now known as the Great Unpleasantness. Police and federal agents stormed the hobbit-hole with search warrants and a decontamination unit. They were stunned to find hundreds of brown jars labeled

with the “dirty pictures” that only chemists could read. Improper storage, ventilation and bookkeeping, general clutter and messiness, and other environmental code violations led to Shulgin losing his license. “Sasha says he gave the license back,” says Daley. “But that may be a technicality—or a point of pride. However it went down, they were there to take it from him.”

Things changed at the hobbit-hole after that. Sasha’s research continued, but at a slower pace, and any work with scheduled chemicals was now strictly forbidden. Jars and vials containing such substances were removed and destroyed, replaced by gaudy pink straws marking their absence. The Wizard went into a funk: He could no longer practice his magic in the unfettered way he once had. He had to work ahead of the law, finding psychoactive compounds that weren’t yet known, that were still technically legal but would soon be made illegal. He continued to share and publish his research, and watched Chinese labs make a small fortune from his psychedelic inventions weeks after the research was published. He privately fumed at the DEA, but he kept quiet and kept his head down. The Wizard was an old man; he didn’t want to spend the rest of his life in court or in jail.

KEEP YOUR SMOKE TO YOURSELF®

smokebuddy®

PERSONAL AIR FILTER

THE pocket size

\$14.95
MSRP

THE ORIGINAL

\$19.95
MSRP

Ideal for:

- Home
- Office
- Travel

Features:

- Pocket Size
- Eliminates Odor
- Removes Smoke
- Convenient
- High Quality
- Reduces Second Hand Smoke

Wholesale opportunities available.
tel: 818.762.6061 email: sales@smokebuddy.com web: www.smokebuddy.com

SHULGIN ARCHIVE PHOTO

ayahuasca with their local circle. "Sasha had a hard time with that one," she says. "I don't think he liked all the different stuff going on, and it just didn't agree with him." Whether it was the constraints imposed by the ritual, the bitterness of the tea, the nausea and heavy hallucinations, or all of that combined, Ann says ayahuasca wasn't for them. "We tried to finish the ritual, which required taking a second dose—so we took a smaller dose and tried to ride it out." Ann remembers very clearly that it did not go well. "Sasha'd had enough by that point, and later in that trip I heard a spirit or a voice in my head telling me, 'Don't come here again.'"

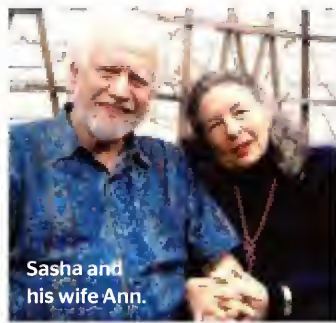

Sasha and his wife Ann.

Shulgin's golden era of unfettered psychedelic exploration continued for more than two decades, his discovery of new chemicals eventually reaching into the hundreds. "He was very proud of his Schedule I DEA research license," Daley recalls. "It was the first thing he showed me when I arrived at the lab in 1977. It was pinned to the wall right inside the door. He just pointed at it and smiled." That little golden ticket gave the Wizard the power to work his magic without interference.

Shulgin had always had a good relationship with the DEA. He was one of their experts—in fact, he was *the* expert; he even taught seminars and wrote law-enforcement reference documents.

But his relationship with the Feds changed in 1991 after he wrote *PiHKAL* (short for *Phenethylamines I Have Known and Loved*), a "chemical love story" and large-scale reference work that chronicled his discoveries in the phenethylamine family, including his star creation, 2C-B. The psychedelic community saw *PiHKAL* as a groundbreaking work of immense importance; the law-enforcement community viewed it as a cookbook. Shulgin was no longer the DEA's expert; now he was everybody's expert. The Feds definitely didn't like that.

The DEA finally decided to revoke Shulgin's Schedule I license in 1995 and raid his alchemical hideaway, an event now known as the Great Unpleasantness. Police and federal agents stormed the hobbit-hole with search warrants and a decontamination unit. They were stunned to find hundreds of brown jars labeled

with the "dirty pictures" that only chemists could read. Improper storage, ventilation and bookkeeping, general clutter and messiness, and other environmental code violations led to Shulgin losing his license. "Sasha says he gave the license back," says Daley. "But that may be a technicality—or a point of pride. However it went down, they were there to take it from him."

Things changed at the hobbit-hole after that. Sasha's research continued, but at a slower pace, and any work with scheduled chemicals was now strictly forbidden. Jars and vials containing such substances were removed and destroyed, replaced by gaudy pink straws marking their absence. The Wizard went into a funk: He could no longer practice his magic in the unfettered way he once had. He had to work ahead of the law, finding psychoactive compounds that weren't yet known, that were still technically legal but would soon be made illegal. He continued to share and publish his research, and watched Chinese labs make a small fortune from his psychedelic inventions weeks after the research was published. He privately fumed at the DEA, but he kept quiet and kept his head down. The Wizard was an old man; he didn't want to spend the rest of his life in court or in jail.

KEEP YOUR SMOKE TO YOURSELF®

smokebuddy®

PERSONAL AIR FILTER

THE pocket size

\$14.95
MIS RP

THE ORIGINAL

\$19.95
MIS RP

Ideal for:

- Home
- Office
- Travel

Features:

- Pocket Size
- Eliminates Odor
- Removes Smoke
- Convenient
- High Quality
- Reduces Second Hand Smoke

Wholesale opportunities available.
tel: 818.762.6061 email: sales@smokebuddy.com web: www.smokebuddy.com

GUTTER CREDIT: XXXXX XXXX

SHULGIN ARCHIVE PHOTO

The last time I saw Sasha was five days before his death. He was in a wheelchair, almost deaf, almost blind, suffering from dementia, and with liver cancer on top of everything else. I told him I had come all the way from Seattle to see him; he kept asking, “*Why? What for?*” He was almost entirely out of breath. I couldn’t tell if he was confused or just playing with me, but it felt like he was reaching for the energy to make another joke.

Always with the jokes, this guy ... even at death’s door. I remember the first time I spoke at length with Sasha, almost 10 years ago, sitting in an Italian restaurant after a conference on psychedelics in San Jose. A young chemist sat next to me asking all kinds of questions, but Sasha only wanted to make jokes—or, worse, puns. “What’s the best time to go to the dentist?” he would ask. “Tooth-hurty.” Sasha could torture people for hours with a steady barrage of these groaners. “He was relentless,” recalls family friend Greg Manning, who spent a magical evening driving around Burning Man in a golf cart with Sasha and Ann. “I kept telling him to stop, and he kept nailing me with one-liners. I was laughing so hard I could barely breathe. He was just destroying me.”

But Sasha couldn’t summon the energy

to make that last joke. I said goodbye and thanked him for everything he had given to the world. He died a few days later.

It’s hard to say what life will be like on Shulgin Farm now that the Wizard is gone. Although Sasha’s published work is available from Transform Press, there are still many volumes of unpublished notes that have never been transcribed. “There are

The psychedelic community saw *PiHKAL* as a groundbreaking work of immense importance; the law-enforcement community viewed it as a cookbook.

dozens of Sasha’s journals in storage,” says Tania Manning, Shulgin’s archivist. “We’re still in the process of cataloging everything.” Tania takes me around the estate and shows me all the plants in the Wizard’s magic garden. Back in the hobbit-hole, Paul Daley keeps the equipment clean and occasionally fires it up to continue Sasha’s work. “I think there’s still great value in researching the duds,” Daley says, referring to the many Shulgin compounds that *should* be psychoactive but, for whatever

reason, aren’t. “These chemicals may have all kinds of secondary effects that have never been explored. These could be fruitful lines of research, but exploration in this area has barely started.”

Those around him have re-formed the Alexander Shulgin Research Institute (ASRI) to preserve his scientific work, but it’s hard to imagine that Sasha’s independent and imaginative style could ever be duplicated by a foundation. Many people think of chemistry as technical and boring, but Shulgin never did. “I’m just a cook,” he would often say—and from the looks of his alchemical hideaway, he liked things messy and exciting. I remember watching Sasha and my chemist friend scrawling a few “dirty pictures” on a napkin in that Italian restaurant. They drew a series of synthesis pathways from one molecule to the next, each one trying to do outdo the other. “It’s so amazing,” I said, looking at the napkin. “Adding and removing atoms from existing molecules turns them into totally different molecules. It’s like you’re rearranging the fabric of reality.”

“That’s it exactly,” replied the Wizard, peering at me from under a bush of crazy white eyebrows. “It’s the closest thing we have to real magic.” ✨



Compton Grinders
www.ComptonGrinders.com

MADE IN U.S.A.

“The Perfect West Coast Cut”



SHORELINE
DEVIL'S HARVEST
SEEDS

www.thedevilsharvestseeds.com
ACQUISITION OF LIVE CANNABIS SEEDS IS ILLEGAL IN THE UNITED STATES
PAYABLE IN US DOLLARS FROM ANYWHERE IN THE WORLD

CloudV

Winner
1st Place Best Product
Medical Cannabis Cup



1-800-707-4206

CLLOUDVAPES.COM





WINNER
HIGH TIMES MAGAZINE
S.T.A.S.H. GEAR OF THE YEAR
AWARDS 2012
"A true innovation and the leader
in the next generation of
automated processors."

AS SEEN ON
You Tube



Meet The Centurion Family



The Li'l Bro
 - New Shark-toothed Horizontal Blade Cutting System
 - Processes 4-6lbs of product per hour
 -MSRP **\$5,495.00**



The Original Centurionpro
 - 2012 Stash Award Winner!
 - processes 8-12 lbs of product per hour
 -MSRP **\$7,495.00**



The Gladiator
 - Double Tumbler Technology
 - Processes 20-30lbs of product per hour
 -MSRP **\$12,495.00**



The Silver Bullet
 - Noise Reduction System
 - Built-in Commercial Grade Infinity Bluetooth Stereo
 - Processes 8-12lbs of product per hour
 -MSRP **\$7,995.00**

1-855-535-0558 WWW.CPROSOLUTIONS.COM

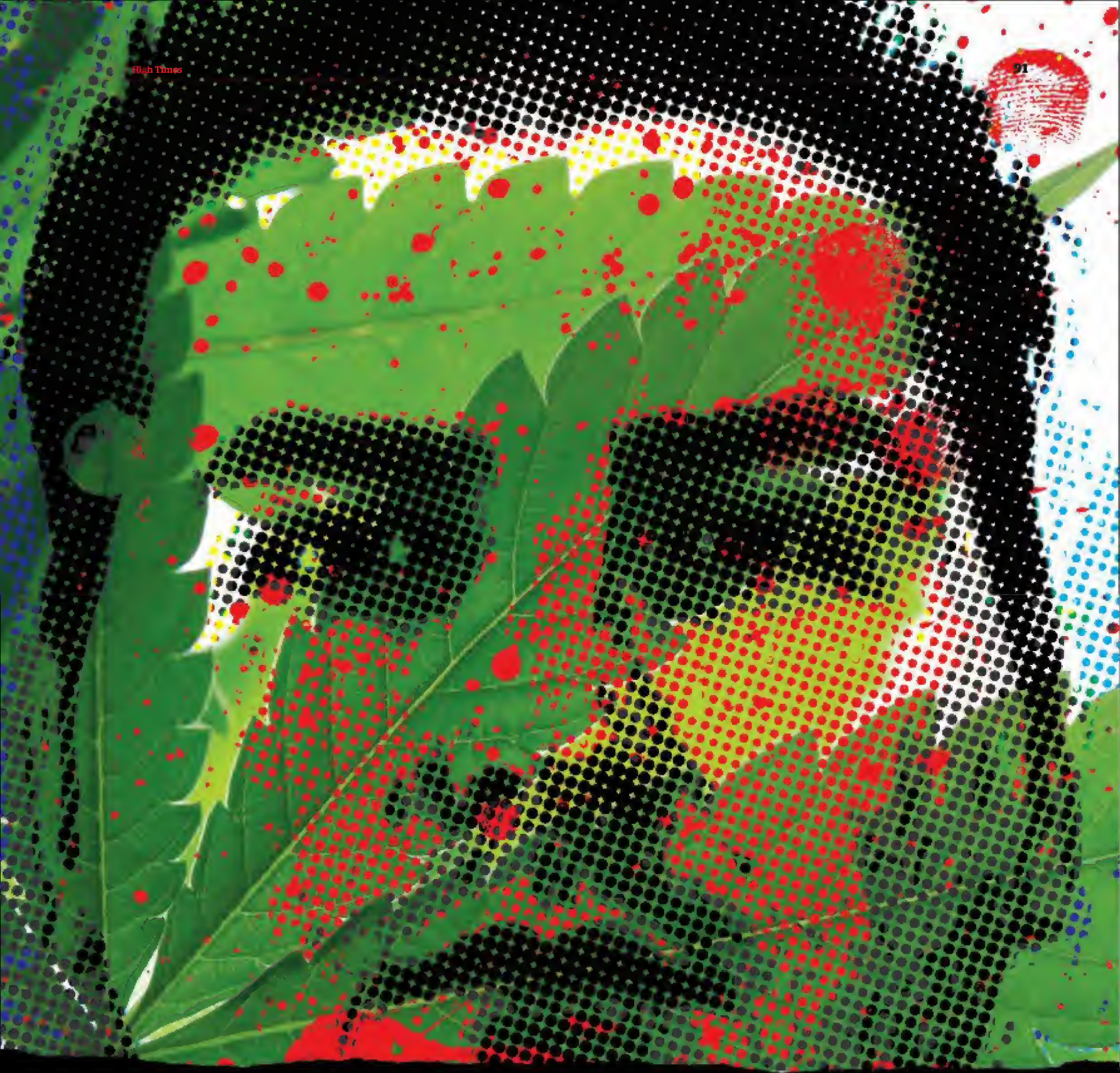

The Fury in Missouri

Last March, a cannabis-friendly Facebook post set off an Internet firestorm after a pet-care company refused to walk the dogs of one of its pro-marijuana customers on the grounds of religious principle. What that pet-care company didn't mention was that, 11 years ago, one of its supposedly devout owners was dismissed from the St. Louis police force after marijuana, crack cocaine and a woman with a bullet in her skull were discovered in his car early one morning. *By Chris Simunek*



Dope and Dogma in St. Louis

“Faith ... Family ... Dogs.”

Those are the words that greet you at the website of Pack Leader, Plus™, which offers pet-care services such as dog walking, boarding, grooming and behavior modification. When you click on the “about” button, there’s a picture of company president Brooke Zeigler snuggling with a dachshund. “Since I started the company,” she writes, “I noticed that all dogs ‘pay it forward’ to another dog who may have poor behavior or manners. They will mirror each other and learn at a rapid pace to blend with the Pack better.”

Promising “exceptional customer service,” Pack Leader, Plus offers the Surveillance Fuzzy Cam®—which allows dog owners to log onto their computers and check out videos of their four-footed friends being cared for. Also of note is the company’s mobile grooming trailer, K9 Cabin Cuts, which is staffed by Brooke’s husband Tom Zeigler, a onetime law enforcement officer who boasts of providing “the best type of cut for each pet and their owners [sic] lifestyle.”

The Pack Leader, Plus website contains many positive testimonials, and even Shawn Moyer—the dog owner who would soon bring unwanted national attention to this small St. Louis

business—has a high regard for the services of Brooke and Tom Zeigler. By his own admission, Pack Leader, Plus was the only dog service in the area capable of attending to the special needs of his two rescued huskies, Bogey and Bacall.

But when the Zeiglers dismissed him as a client over an innocuous cannabis-themed Facebook post, not only was Shawn Moyer insulted at the implication that he and his family were in some way involved with drugs; he suddenly found himself in the undesirable position of not being able to plan future vacations for lack of a proper venue to board his dogs.

But Moyer would have his revenge. Soon, his discontent was beamed across the information superhighway, and a long-buried skeleton from Tom Zeigler’s past would be disinterred and paraded for all to see. It’s a cautionary tale, to be sure—and if you, dear reader, take away two things from this story, the first should be a reminder that the Internet never forgets; and the second, a warning that hell hath no fury like a dog owner scorned.

One might also keep in mind the wisdom of Scripture, specifically Matthew 7:1: “Judge not, lest ye be judged.” So I guess that’s three things, but math was never my strong point.

Cookies and Meme

It all started when 13-year-old Danielle Lei and her mother set up a table to sell Girl Scout cookies outside the Green Cross medical marijuana dispensary in San Francisco last February. Danielle’s sugary merch proved irresistible to the Green Cross clientele, and she managed to sell 117 boxes of the famous sweets in less than two hours. The story spread quickly throughout the blogosphere: It was the kind of post that the Facebook “share” button was invented for—a cute picture that provided a quick laugh and a fleeting acknowledgement that someone out there had found an ingenious way to make a buck off the stoner stereotype.

One person who found the story amusing enough to pass on was Trish Moyer, a speech pathologist, Girl Scout troop leader and the mother of two young girls. But the simple act of posting that photo on her Facebook page set off a firestorm after she was caustically dismissed as a client by her dog-walking service—the aforementioned Pack Leader, Plus—for offending the religious sensibilities of its two owners, Brooke and Tom Zeigler.

This summary exile from Pack Leader, Plus presented Trish’s husband Shawn with a dilemma. Sure, he could try to find another dog-walking service,



Humboldt Seed Organization



H50

Blue Dream

feminized

by B REAL of
CYPRESS HILL

Dr Greenthumb's Em-Dog

feminized

H50

Green Crack

feminized

H50

Sour Diesel #2

feminized

H50

Desert Diesel

feminized

H50

Amherst Sour Diesel

feminized

H50

Purple Trainwreck

feminized

H50

Lost Coast Hashplant

feminized

H50

Lost Coast OG

feminized

ACQUISITION OF LIVE CANNABIS SEEDS IS ILLEGAL IN THE UNITED STATES | PAYABLE IN US DOLLARS FROM ANYWHERE IN THE WORLD.

WWW.HUMBOLDTSEEDS.NET

WITH LOVE FROM CALIFORNIA

ACQUISITION OF LIVE CANNABIS SEEDS IS ILLEGAL IN THE UNITED STATES | PAYABLE IN US DOLLARS FROM ANYWHERE IN THE WORLD.

DINAFEMSEEDS

WWW.DINAFEM.ORG



info@dinafem.org



+34 943 21 86 88



facebook.com/dinafem



@dinafem

 NEW CRITICAL+ 2.0 AUTOFLOWERING 25€ 3	 NEW CRITICAL CHEESE AUTOFLOWERING 22€ 3	 NEW BLUE CHEESE AUTOFLOWERING 20€ 3	 WHITE WIDOW AUTOFLOWERING 22€ 3	 CHEESE AUTOFLOWERING 18€ 3	 WHITE CHEESE AUTOFLOWERING 19€ 3	 MOBY DICK AUTOFLOWERING 25€ 3	 ORIGINAL AMNESIA AUTOFLOWERING 22€ 3
 HAZE 2.0 AUTOFLOWERING 23€ 3	 CRITICAL+ AUTOFLOWERING 25€ 3	 NEW DINACHEM 27€ 3	 NEW DINAMEX 25€ 3	 NEW KUSH'N'CHEESE 21€ 3	 NEW DEEP CHEESE 21€ 3	 NEW BLUE CHEESE 20€ 3	 NEW BLUE THAI 24€ 3
 NEW OG KUSH 25€ 3	 ORIGINAL AMNESIA 26€ 3	 NEW CRITICAL+ 28€ 3	 MOBY DICK 33€ 3	 NEW CHEESE 21€ 3	 NEW CRITICAL JACK 23€ 3	 NEW WHITE WIDOW 25€ 3	

but Bogey and Bacall didn't really *do* walks. As strays that had been rescued from the purgatorial shelters of St. Louis, they needed vigorous exercise—they needed to *run*—and after contacting nearly 20 other services, Moyer found that the Zeiglers were the only handlers who would agree to indulge his dogs' bestial nature.

On February 28, Shawn sent Tom Zeigler a message via Facebook asking for a reprieve: "We REALLY like working with you guys And for our particularly unique furry family members, we'd basically be up the creek if we couldn't rely on you."

Tom Zeigler's response was stern and unyielding. The Zeiglers were "upset by the pic with the girls [sic] scouts selling cookies outside of a government funded drug house [because] they knew a bunch of whacked out dope fiends would buy a bunch of cookies. We think this is appalling and not funny or cute. [It's] just a disgusting use of children to make more money on the back of drug addicts ... for us, it [is] a religious belief which we will not violate by coercion of man or government."

Shawn felt betrayed. He'd let the Zeiglers' kids swim in his pool while he was

The Zeiglers were "upset by the pic with the girls [sic] scouts selling cookies outside of a government funded drug house."

out of town. He'd agreed to let Bogey and Bacall be photographed for a book the Zeiglers had compiled. But for Tom Zeigler, the issue transcended such niceties.

"Our stance towards drugs of any kind is zero," the ex-policeman wrote back. "If you or your family or anyone you could come in contact with is involved in that we can no longer service you. if your belief is this behavior is okay we can no longer service you ... we will take a stand to our last breath on this topic."

Shawn Moyer was highly displeased with this response. After decrying Tom's actions as "mind-bogglingly [sic] hypocritical for someone who talks so much about their Christian faith," he climaxed his fury with the wish that "a pox" would descend on the Zeiglers' home.

Glass Doghouses

On March 11, I received an email via the *High Times* website that brought this story to my attention. As the email contained only web links with little explanation, I mistook it at first for spam. Then two cryptic sentences and a signature at the bottom caught my eye:

St. Louis County police officer Patricia March was fighting for her life when the question came: Who shot you?

Thomas S. Zeigler shot Patricia March in the face.

Beneath that, it was signed:

*Arigato!
Emma*

The first link took me to an article in the *Riverfront Times* entitled "Dog Walkers to Client: 'We Don't Walk Dogs For People Who Want Marijuana Legalized.'" Shawn Moyer had contacted the *Times* himself: He wanted his indignation chronicled by the local paper of record.

It was the third link, however, that provided the most salacious reading. It described the details of an incident that

ITAL HEMP WICK
ItalHempwick.com

MADE with ORGANIC HEMP and BEESWAX

- An all Natural Hemp Smoking Wick.
- Allows for Full Flavored Smoke.
- Keep it clean Healthy and Butane Free.
- A Must for all Smoking Enthusiasts.

Available at better smoke shops Nation Wide.
FOR A FREE SAMPLE: Check out the website or Send a self addressed stamped envelope to:
I-Tal Hemp Wick Dept. HT, P.O. Box 525
Kealahou, HI 96750

the original
I-TAL HEMP WICK
MADE WITH ORGANIC HEMP & BEESWAX

Find us on Facebook

High N' Dri

BHO to OMG

Use High N' Dri™ to transform your oily herbal extract into a fine free flowing powder. Excellent for use in edibles. Superb for smokables!

Order now!
at www.high-ndri.com

High N' Dri™ is designed for use with herbal extracts and concentrates. Actual results may vary. See product label for details or visit www.high-ndri.com. High N' Dri™ is a trademark of AgriBotanics, USA. Copyright © 2014 - All Rights Reserved. Graphics by BoomBrusher Designs. BoomBrusher.com



Buddha s e e d s



NEW PACKAGING!

**DIVISIBLE BLISTERS!!
MAKE YOUR OWN PACK OF SEEDS**

NEW!

Magnum
1 Feminized Seed: 8€
10 Feminized Seeds: 70€
50 Feminized Seeds: 290€

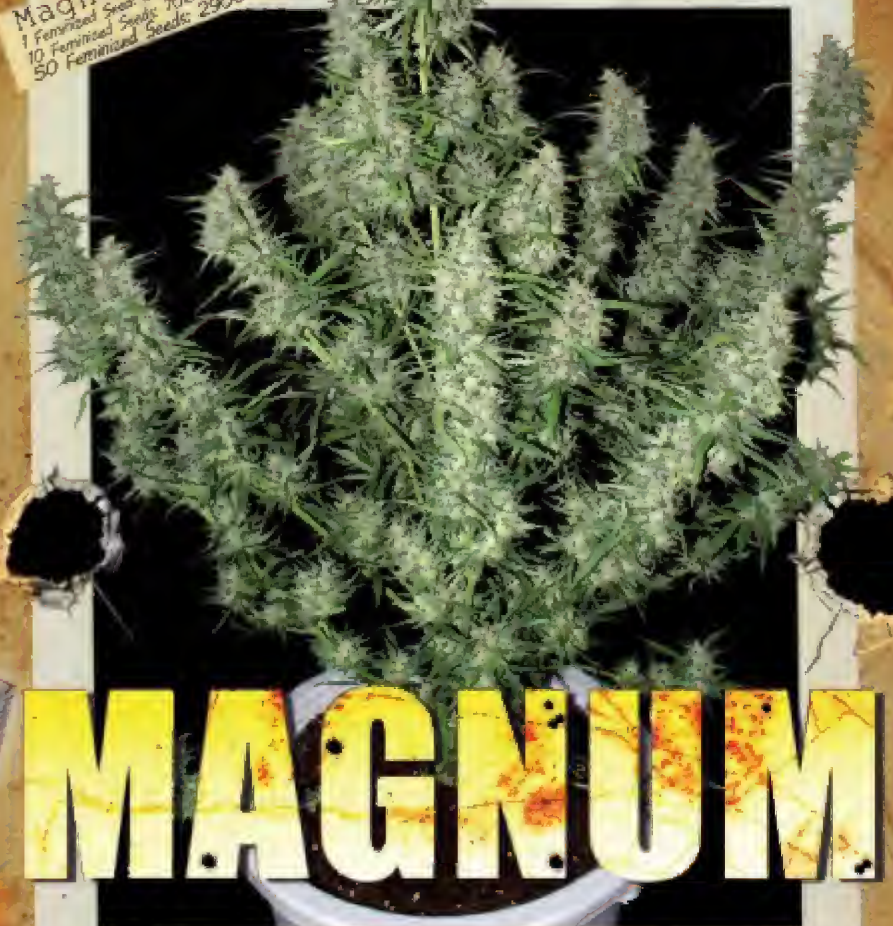

MAGNUM

**THE MOST POWERFUL AND PRODUCTIVE AUTO
THAT HAS EVER EXISTED**

Autoflowering



White Dwarf
1 Feminized Seed: 7€
10 Feminized Seeds: 60€
50 Feminized Seeds: 245€

Autoflowering



Red Dwarf
1 Feminized Seed: 6€
10 Feminized Seeds: 52,50€
50 Feminized Seeds: 215€

Autoflowering

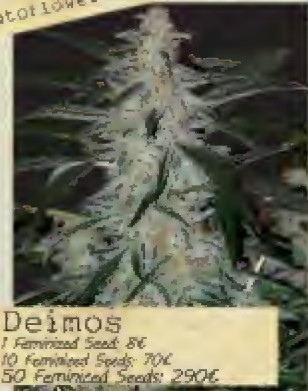

Deimos
1 Feminized Seed: 8€
10 Feminized Seeds: 70€
50 Feminized Seeds: 290€

Autoflowering



Syrup
1 Feminized Seed: 7€
10 Feminized Seeds: 60€
50 Feminized Seeds: 245€

Autoflowering



B.Purple Kush
1 Feminized Seed: 7€
10 Feminized Seeds: 60€
50 Feminized Seeds: 245€

Autoflowering



Assorted Auto
10 Feminized Seeds: 35€
50 Feminized Seeds: 145€

Autoflowering



Quasar
1 Feminized Seed: 8€
10 Feminized Seeds: 70€
50 Feminized Seeds: 290€

Autoflowering



Pulsar
1 Feminized Seed: 8€
10 Feminized Seeds: 70€
50 Feminized Seeds: 290€

www.buddhaseedbank.com



ACQUISITION OF LIVE CANNABIS SEEDS IS ILLEGAL IN THE UNITED STATES - PAYABLE IN US DOLLARS FROM ANYWHERE IN THE WORLD

occurred on March 3, 2003, when law enforcement was called to a disturbance near the Oakville residence of a policeman named Tom Zeigler. Upon inspection of his Nissan Pathfinder, the cops discovered fellow St. Louis County police officer Patricia March bleeding profusely from a wound inflicted by a .40-caliber bullet from Tom Zeigler's Glock, which had been fired at point-blank range into her face, obliterating her left eye and nicking part of her brain. Zeigler and March, it turned out, had been dating for about three weeks.

Remarkably, Patricia March was still conscious and speaking, albeit incoherently.

Upon questioning by the police, Zeigler—who, at 5:23 a.m., had been found at the scene in his sweatpants, drunk and holding a towel to his fellow officer's wound—was vague on details. After obtaining a warrant to search the Pathfinder, investigators discovered empty beer bottles, crack and marijuana pipes. They also found a bag labeled “Police Officer of the Month,” that contained 1.64 grams of cocaine and nearly a quarter-ounce of pot.

One assumes that the religious Zeigler embraced Jesus and His anti-drug

message sometime subsequent to that night.

When Zeigler's supervisor, Sgt. Robert Shelvey, arrived and inquired into the whereabouts of the gun, Zeigler led him into his apartment, where it was found in a fanny pack on the floor. Entering the bedroom, Shelvey discovered a blood-

They also found a bag labeled “Police Officer of the Month,” that contained 1.64 grams of cocaine and nearly a quarter-ounce of pot.

stained bedroll and evidence of blood on one of the walls. Since Officer March had been shot in the Pathfinder, the scene offered more questions than answers.

Unfortunately for Sergeant Shelvey, Tom Zeigler's apartment was not equipped with a Surveillance Fuzzy Cam®, which might have shed light on the circumstances. Patricia March later testified that, while she was in a blackout state, Tom Zeigler had brutalized her

sexually before the shooting, slashing her with a razor and carving the initials “TZ” into her abdomen.

For his part, Zeigler gave several accounts of the shooting that night before settling on a scenario in which March grabbed the gun from the backseat and shot herself in the face. Despite his obvious drunkenness and the fact that a bullet from his gun had been fired into a fellow officer, Zeigler was never tested for alcohol. March's blood-alcohol content was determined to be .349 percent.

Let's put that number in perspective. When Mel Gibson, director of *The Passion of the Christ*, was pulled over for driving under the influence in Malibu and informed a Jewish cop that “Jews are responsible for all the wars in the world,” he registered .12 percent on a breathalyzer test. Then there's country star Randy Travis, who, having been found drunk, naked and bleeding in the road after crashing his Trans Am in Tioga, TX, threatened to kill the state troopers who arrested him. On that fateful night, which produced one of the most memorable celebrity mug shots in history, the 53-year-old country star's score topped out at .21 percent. And at the time of her death from alcohol poisoning, singer Amy

PULSAR[™]
www.PulsarVaporizers.com

Free Shipping in USA

LUX

3 TEMPERATURE SETTINGS

CELEBRATING 15 YEARS

Made in the **USA** since 1998

THE URINATOR™

FOR HIM

**IT'S NOT
A DRINK
OR
AN ADDITIVE!**

FOR HER

**DIGITALLY
CONTROLLED
REUSABLE
ELECTRONIC
DEVICE!**

Only device on the market guaranteed to electronically regulate proper temperature.

*** We do not sell unreliable organic heatpads

The Urinator 149.95

*** comes with 1 free sample Dr. John's Synthetic

OUR SYNTHETIC HAS THE BEST RECORD IN THE INDUSTRYPERIOD !!!

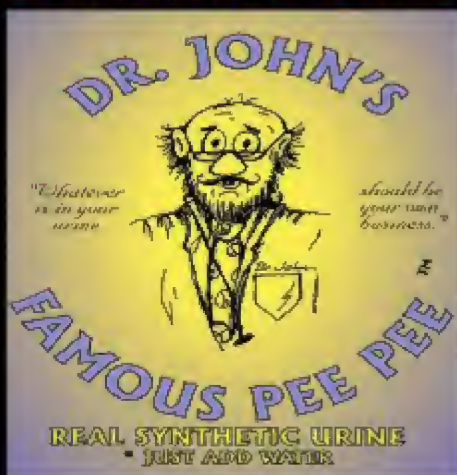

Dr. John's synthetic urine is the absolute finest substitute available on the market. We haven't changed our formula in 15 years. We did it right the first time!

WE DO NOT HAVE FAILURES

Dr. John's synthetic \$10.00

NEW.... CAR ADAPTER (FITS ALL URINATOR MODELS) \$39.95

**save your batteries for when you need them!

CONTAINS URIC ACID.....ALWAYS HAS !!!

800-395-1694

WWW.URINATOR.COM

The urinator and Dr. John's synthetic is manufactured and sold for protecting the user from genetic discrimination. It is not designed, manufactured or intended to be used to defeat a drug or alcohol screen. The Urinator is not a medical device.

Winehouse's blood-alcohol content was .4 percent—just .051 percent higher, or one strong drink more, than Patricia March's level on the night of the shooting.

Most likely March's state of intoxication means she was incapable of consenting to sex, let alone shooting herself. She believes that Zeigler slipped her a date-rape drug, and that she was drinking and/or plied with alcohol while she was under its influence. When she was finally able to tell her story, March claimed that Zeigler—who had filed for divorce from his wife the same week—shot her after she attempted to break up with him.

In the end, what punishment was meted out to the perpetrator by the halls of justice in St. Louis? Convicted of second-degree assault, felony possession of cocaine and misdemeanor possession of weed, Tom Zeigler was sentenced to three months for the coke, and fined \$500 for the weed and another \$5,000 for the bullet he fired into Patricia March's skull.

Cyber Warfare

"We simply said it was against the idea of being clean and sober-minded and treating your body as a temple to the Holy Spirit. I guess Mr. Moyer, who is a

Tom Zeigler was sentenced to three months for the coke, and fined \$500 for the weed and another \$5,000 for the bullet he fired into Patricia March's skull.

devout atheist, took serious offense to our religious standings."

Such was Tom Zeigler's reply when a reporter from the *Huffington Post* picked up on the saga of Shawn Moyer and his two dogs' exile from Pack Leader, Plus. Zeigler, at this point, must have been wondering how in the world he'd gotten into this mess.

"Currently all the drug supporters are bombing our Pack Page with disgusting drug stuff and attacking our Christian beliefs," he posted on the Facebook page that he and his wife share. Someone had created a nearly identical Facebook page entitled "Pack Leader, Plus (unofficial)," which carried the Pack Leader address and phone number, negative Yelp reviews, pictures culled from the Zeiglers' own Facebook page that showed

them drinking alcohol at various events, and links to all of the articles concerning the Moyer/Zeigler bitchfight as well as Tom Zeigler's arrest and prosecution for shooting Patricia March. For good measure, there was a link to a *High Times* article regarding the benefits of medical marijuana.

On his real Facebook page, Tom Zeigler expressed dismay that "something from over a decade ago" had been dredged up in the kerfuffle. "Only a handful of people know the truth about that particular incident," he added, "and I was taking a stand against corruption at the time and it was used against me and I lost everything."

One person who definitely knows "the truth about that particular incident" is Patricia March herself. After tracking her down on Twitter, I asked her if it was at all possible that, as he suggests, Tom Zeigler had gone rogue, Bruce Willis style, in some kind of lone-wolf campaign to clean up the St. Louis police.

"Oh, hell no," March replied. She said she'd suspected Zeigler of being a dirty cop before the shooting, including planting drugs on suspects. That, and an incident in which Zeigler punched her in the face, convinced her to break off the affair.

"He said something to me one time

GROW SHED

Do It Yourself

*AVAILABLE 8'x12' and 10'x16'
*CHECK OUR WEBSITE FOR PRICE

365

Light Deprivation Greenhouse





Grow Shed
45,000 LUX



1000w HPS
10,000 LUX



ACHIEVE COMPLETE BLACKOUT
AUTOMATICALLY IN SECONDS!

STARTING AT: \$3860

- SAVE MONEY - No lighting costs!
- SAVE MONEY - Low electrical costs

POWERED BY THE MOST EFFECTIVE GROWING LIGHT AVAILABLE: THE SUN

BLACKOUT
greenhouse

1-855-GROW-LAB (476-9522)
blackoutgreenhouse.com

HARVESTER

Light Deprivation
Greenhouse

365



ENERGY EFFICIENT 22 SEER
Remote Controlled Heating & Cooling

VAPE OREGON

Vape OR

"MORE TASTE TO YOUR BUDS"
Variable Heat Control Kits

BEST QUALITY & LATEST TECHNOLOGY

RETAIL & WHOLESALE

ONE YEAR WARRANTY

Mini Vaporizer Kits
Wax/Oil
Dry Herb/Hash
Liquid

New Vape Colorado Edition

Vape Oregon

Variety of Heating Coils
100% SAFE

vapeoregon.com
DISCOUNT CODE: HIGHTIMES

facebook.com/vapeoregon youtube.com/vapeoregon @vapeoregon

FRESH LOOK

PROVEN RESULTS

While the packages are new, Europonic products are the same highly-concentrated plant nutrient supplements used to promote vigorous plant growth.

Nitrozime[®] Marine Algae Extract contains over 50 trace minerals and macro nutrients. Long known to farmers for its rich value, seaweed feeds plants with a wide range of nutrients, growth bio-stimulants and conditioners. At the root level Nitrozime[®] stimulates beneficial soil microbe activity while providing important nutrients. When used as a foliar spray, Nitrozime[®] is immediately absorbed through leaves for maximum beneficial effect.

FossilFuel[®] Humic Acid is derived from Leonardite, a rare form of lignite coal made of ancient plant materials and the best source of humic acids. FossilFuel[®] promotes healthy soils and growing media which in turn help to produce lush plant growth and expansive root systems.

Rockwool Conditioning Solution contains a premium blend of pH controls and pure mineral salts, which are ideal for pre-conditioning rockwool and stonewool growing media products before starting seeds, clones, and transplants.

The Europonic line provides the premium nutrients your plants require for vigorous, explosive growth. Available at Hydro Stores Nationwide. hydrodynamicstl.com

HYDRO DYNAMIC STLS

SUPERCLOSET
#1 Selling Grow Boxes in the World



SuperLocker LED
66" h x 15" w x 24" d

FEATURING 

KIND LED
GROW LIGHTS

FASTEST YIELDS
700 mA Driving current diode efficiency and output, resulting in a brighter, higher yielding footprint

OPTIMAL SPECTRUM
Proprietary 12 band complete "Perfect Spectrum" powered by 3 watt diodes

HIGHEST INTENSITY
Secondary optical lens magnifies PAR and increases canopy penetration by up to 200%

Great Quality
Extra large heat sinks, quiet fans, precision drivers, superior craftsmanship

ONLY LED GROW LIGHT THAT HAS BOTH IR & UV TECHNOLOGY!

SuperLocker Video 

www.supercloset.com
P.O. Box 883663 ph. + 877. 476 29787
San Francisco, CA 94188 Fax. + 415. 285. 0301

about if he would ever get dragged into the station and questioned," she explained, "or if Internal Affairs would get involved, if I would please get the 'Police Officer of the Month' bag from the back of his Pathfinder. I started catching on."

It has been a nightmare 11 years for Patricia March. No one believed she would survive the shooting, and she was given last rites three times during the 14-hour operation that followed. It has taken numerous surgeries to restore her face. Shrapnel was removed, a glass eye implanted. Bullet and bone fragments remain in her brain. On September 10, 2008, the St. Louis County Police fired her for having sex while on duty with Zeigler in 2003, before the shooting. Suffering from post-traumatic stress disorder and agoraphobia, Patricia March remains "deathly terrified" of Tom Zeigler to this day.

"I'm just waiting for the hammer to drop when he does something worse," she said.

Dog vs. Troll

After reading the links that the mysterious "Emma" sent me bringing this story to my attention, I emailed her back and was sent several more—along with Shawn Moyer's email address.

When I asked Moyer what the real story was here—aside from a pretty shady ex-cop refusing to walk his dog because of a Facebook post—he replied: "The way I see it, this is about a sort of ongoing culture war in the US, the religious right and other folks who don't want to believe in 'live and let live' versus, well, everyone else."

After talking to Moyer, I messaged the "Pack Leaders, Plus (unofficial)" page on Facebook asking for an email contact for Tom Zeigler, and was sent Brooke's email address almost immediately. (Tom Zeigler did not respond to an interview request.) Curious as to who was behind the phony

Pack Leaders page, I asked the person on the other end for their name. Perhaps I shouldn't have been surprised by the answer: "This is Shawn [Moyer] but there are 4 people with admin to this page.

Plausible deniability?"

If it was, in fact, Moyer, it would seem that the moral high ground he'd staked out in the press wasn't enough: He felt the need to plant a flag in the murkier territories of social media as well. In the nanocosm of St. Louis pet-care circles, perhaps he did strike a blow for freedom of expression—but the "drug supporters" who saw reason to wade into this fight on his side ended up being duped by a troll.

Bogey and Bacall's master wants all the pro-pot folks who rallied to his cause to know that he is grateful for their help in swinging fortune his way. On *Marijuana.com*, in the comments section beneath a story denouncing the "weed racism" that the Moyers and their dogs were subjected to, a comment under the name "Whacked-Out Girls Scout Dope Fiends" reads:

Thanks for the support, y'all. After the article came out we had a ton of offers to take care of our dogs, even for free, from folks willing to travel to Saint Louis from all over the country.

In the end, this story has an unsavory conclusion, since there is no real justice here. Having given voice to his indignation, Shawn Moyer is free to vacation again without worry, knowing that there are legions of supporters who will pamper Bogey and Bacall in his absence. Tom Zeigler, who paid the princely sum of \$5,000 to shoot a woman's eye out, continues to serve the public, albeit in a diminished capacity, clipping the hair and toenails of dogs. And the person who suffered the most by far—Patricia March—spends her days afraid to leave her home, lest she be targeted anew by the unknowable evils that lurk outside her door. ✨



Suffering from post-traumatic stress disorder and agoraphobia, Patricia March remains "deathly terrified" of Tom Zeigler to this day.

Green House
Seed Co.®

presents

SPECIFICALLY ENGINEERED
BY THE GREEN HOUSE SEED COMPANY

POWDER
feeding®
keep it simple

EXCLUSIVE DISTRIBUTOR: WWW.RAMBRIDGE.COM
AWARD WINNING NUTRIENTS

RAMBRIDGE™
GROWING THE FUTURE



NOW AVAILABLE
IN NORTH
AMERICA!



AWARD WINNING PLANT FEEDING

Maximum yield, maximum resin production, minimum effort.



LIKE US ON FACEBOOK!
facebook.com/POWDERFEEDING



FOLLOW US ON INSTAGRAM!
instagram.com/GREENHOUSESEEDS



WATCH US ON YOUTUBE!
youtube.com/GREENHOUSESEEDS

WWW.POWDERFEEDING.CH

ACQUISITION OF LIVE CANNABIS SEEDS IS ILLEGAL IN THE UNITED STATES | PAYABLE IN US DOLLARS FROM ANYWHERE IN THE WORLD.



INTERVIEW BY
JASON HARRIS
PHOTOS BY CHAD BOUTIN

BOB SNODGRASS

THE HIGH TIMES INTERVIEW



ALL HIM THE “GODFATHER OF GLASS.” MOST SERIOUS GLASSBLOWERS SPEAK IN REVERENTIAL TONES OF BOB SNODGRASS, THE LEGENDARY GLASS ARTIST WHO PIONEERED NEW TECHNIQUES AND DEvised A HOST OF MODERN GLASSBLOWING TOOLS.

BOB’S INNOVATIONS LAUNCHED THE MODERN PIPE MOVEMENT, AND MANY ARTISTS CITE HIM AS THEIR INSPIRATION. HE HAD PLAYED AROUND WITH GLASS IN THE PAST, BUT MOSTLY DABBLED IN WOODWORKING AS HIS CREATIVE OUTLET. BOB SAYS IT WASN’T UNTIL 1981 THAT HE BEGAN TO CONCENTRATE SERIOUSLY ON GLASS ART.

IN THE STUDIO, HE DISCOVERED THAT SILVER AND GOLD SPRAYED INTO HARD GLASS WOULD CHANGE COLORS WHEN THE BACK WAS BLACKENED. “I’M AN INVENTOR,” BOB SAYS. “I GOT STUCK IN GLASSBLOWING BECAUSE THERE ARE SO MANY THINGS TO INVENT IN IT. I INVENTED A NEW FIELD IN GLASS—THE GLASS I WORK WITH IS ACTUALLY A SPINOFF OF SCIENTIFIC GLASS. IN THAT PROCESS, I FOUND THAT SILVER AND GOLD COULD BE BLENDED AND SPRAYED INTO THE GLASS. A NEW TECHNIQUE OF SPRAYING METALS INTO GLASS CHANGED THE PARAMETERS OF COLOR POSSIBILITIES.”

FORGET WOOD AND METAL: THE CANNABIS COMMUNITY WAS SMITTEN WITH THE COLORFUL NEW GLASS PIPES, AND A THRIVING MARKETPLACE WAS BORN. BUT MORE IMPORTANTLY, A NEW COMMUNITY OF ARTISTS SET TO WORK BRINGING INTO EXISTENCE ANY WHIM THAT FLITTED THROUGH THEIR BRAINS—OFTEN IN JAW-DROPPING GLASS DETAIL.

BOB HAS TAKEN ON MANY APPRENTICES. HE’S NEVER WANTED TO KEEP THE SECRETS OF THE CRAFT TO HIMSELF, AND HE ENJOYS A HUGE EXTENDED FAMILY OF GLASSBLOWERS. FOR THIS INTERVIEW, ONE OF HIS FORMER STUDENTS CAUGHT UP WITH HIM AT HIS SURPRISE BIRTHDAY PARTY. WITH SIGNATURE MODESTY, BOB GAVE US A GLIMPSE INTO HIS WORLD OF GLASS.

Tell us how you got to where you’re at right now.

Should I go back to before kindergarten, when my mom called me her “little artist” who did glass bubbles with an alcohol lamp from a Gilbert Chemistry Set?

As far as you want to go.

In our freshman year, we learned how to bend small-millimeter rods and tubing in a Bunsen burner. When the chemistry teacher left the room, we would roast marshmallows on glass-string rods.

Where was this?

Ohio ... way, way long ago. What was I doing when I really entered into glass as part of my life? I guess I was working a straight day job and trying to find the artist inside. By night, my wife and I had a candle factory in our kitchen and sold candles to local stores. One Memorial Day, Marie and I took off and hitchhiked down to Tennessee from Akron, just to see how they made their candles. My day job was at a gasket-and-shim company.

Some days, I ran a punch press. Most days, I operated a heat-treatment unit. I’d heat copper rings and soften the copper for stretching. I also cast a lot of small lead pieces into brass laminates and ran a surface grinder. Some of the copper filings I made with that grinder were less than a hundred-thousandth of an inch—like liquid. My friend Chuck had been working part-time burning glass, blending it into the clear glass. We thought we were going to make something like

goldstone. No goldstone here. But we did produce red glass rods. We were excited.

Then we started to run out of propane. The color of the rod went from an opaque red to a transparent green. That was our first blast mystery. We later learned that the chemistry of the flame caused a violent swing in the copper, changing how the glass and copper bonded. This type of experimentation later led me to create a small palette of color that I would use as highlights for my glass. That was probably what led me from working in a machine



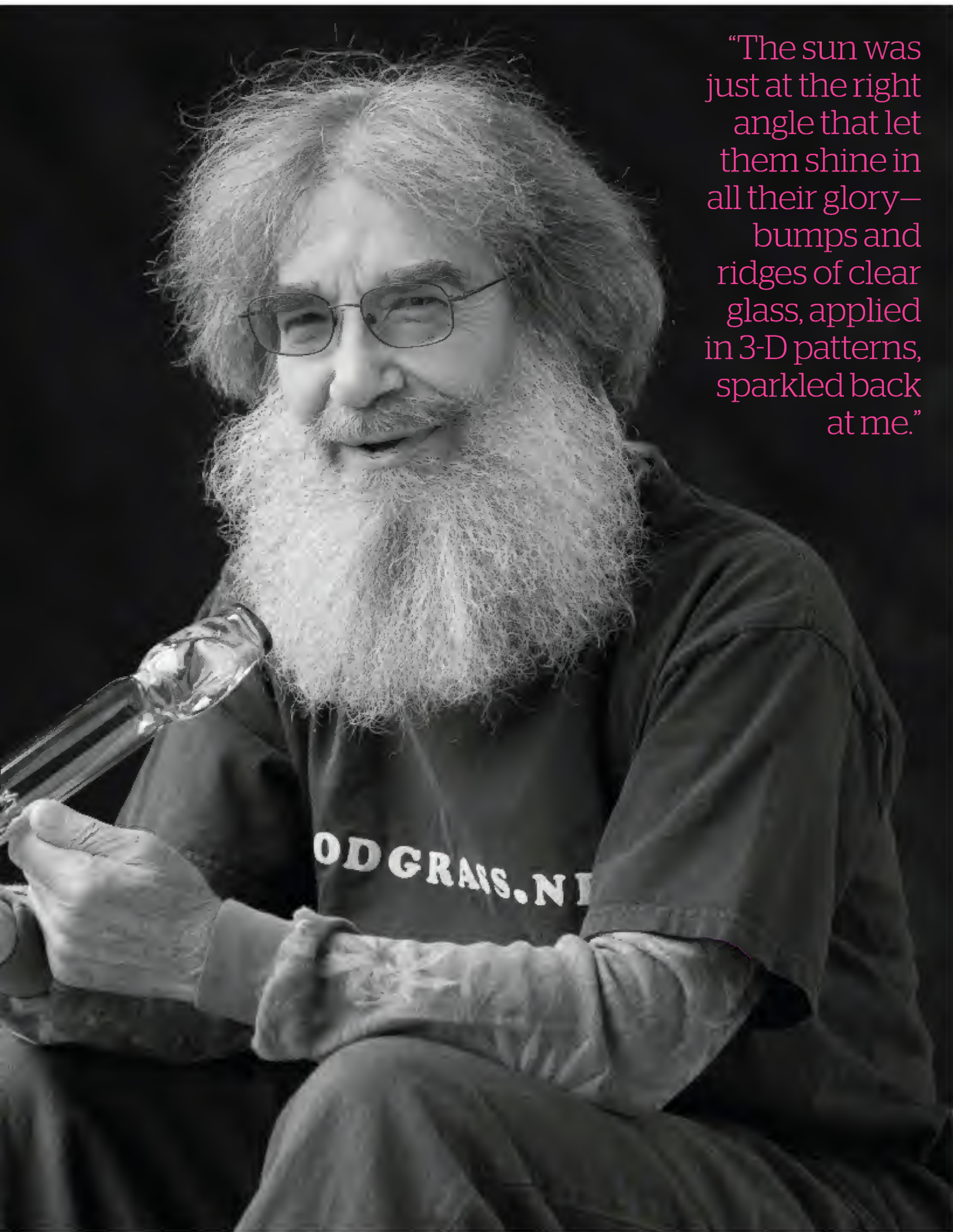

“The sun was just at the right angle that let them shine in all their glory—bumps and ridges of clear glass, applied in 3-D patterns, sparkled back at me.”

shop to working part-time with Chuck—and onward from there.

Was there one revelation that convinced you to change careers and move into glass?

When I first saw glass pipes, I'd been smoking herb about a year. I remember looking in a basement shop window in Akron in 1971. The sun was just at the right angle that let them shine in all their glory—bumps and ridges of clear glass, applied in 3-D patterns, sparkled back at me. Down the steps and in I went. A fellow with a beret sat at a torch, working. He said he'd be with me in a minute. I said, "Wait—I want to see what you're up to."

I introduced myself, and he told me most cats called him Chuck Murphy.

I asked him if he wanted to smoke a doobie ... found out we had a lot in common. Soon I was stopping in the shop on my way home from my regular job. I put some of my candles on consignment in Chuck's shop. One day, he said he was planning a wholesale trip to Youngstown and Pittsburgh and asked if I wanted to take my candles along. From there, we were out every weekend. We hit cities like Ann Arbor, Lansing, Detroit, Columbus, Dayton, Cincinnati—and, of course, Akron, Cleveland and Toledo. We got around.

Then Chuck said, "You know where the shops are. How about *you* take the glass next time?"

Wasn't very long before I came back with the biggest order Chuck ever had. Next day, when I showed up, he told me, "Orders like this aren't easy." We walked into the shop, and two torches were set up. When he lit my torch the first time, this is what Chuck said: "Fire burns and glass cuts."

You do realize you're a legend to thousands of people?

I don't think I'd go that far. I've maybe demoed in front of

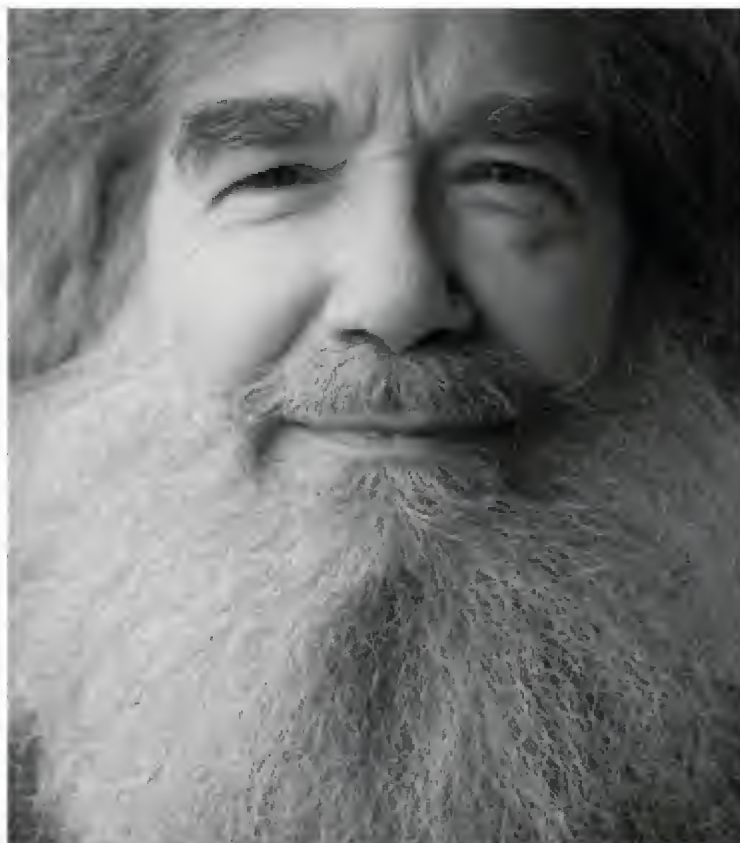

"I've always believed in sharing information. Some of that openness has rubbed off on the people in the field."

thousands, but probably only a few hundred people have come to my studio or taken a class from me in some other situation.

Is there anything that's annoying or frustrating to you in the glass industry?

I don't really see it as a "glass industry"—I kind of see it more like the "trade-show industry," the "smoke-shop industry." The smoke-shop industry has created a field where I and thousands of individual glassblowers can work. Some glassblowers work in shops small and large; some work in workshop mills, never getting to do experiments. Many just work in their own space, maybe with a friend or two, producing whatever they can create a market for.

Do you think Americans are still superior pipe-makers?

American art is superior, but I've always believed in

sharing information. Some of that openness has rubbed off on the people in the field. Sometimes the openness or sharing of an idea helps create a larger idea. Now there are glass shows and competitions in cities all around North America.

Here in Eugene, OR, we have a glass school and several co-op studios that teach classes. Cornerstone Glass hosts several events. We've got Glass Stock. There's the American Scientific Glassblowers Society—their annual convention is going to be here.

With all these events, we end up sharing a lot more. I remember one time, at a world competition in Vegas, one team ran short of material. A competitor—yeah, a *competitor*—gave them the needed glass. I was sitting with a friend of ours, a fifth-generation glassblowing lamp worker. He said, "You'd never see that in Europe."

Does the fact that glass pipes are illegal bother you?

That's not my job, of course. I've felt concern. I hope that the legislation catches up and takes archaic laws off the books, and that we can move in a proper direction toward lining up with the cannabis legalities.

Cannabis may become legal in Oregon this November, but glass pipes still wouldn't be.

I hope it's like the "blue laws" back east: Their time runs out and you take them off the books forever without having to go through legislation.

Uncolored glass has been a popular movement since about 2005. What do you think about it?

The uncolored movement resembles scientific apparatus, where you work at procedure and do the least distortion to a piece as possible. You can produce pieces with really clean lines and a crisp appearance. But I'm kind of a flowers guy. I *work* glass—I make it multi-glitter. I include glitters of silver and gold, reduce it to a molten glob and work on the edge of out-of-control—and then restore the shape to something I like.

That's what everybody loves about your style.

I don't plan to change my style for a better trend.

As an artist, is there a stigma because you're the guy making pipes used for pot?

Stigmas come and go. It doesn't really hurt or interrupt me.

Which artists impress you right now?

Too many of them—it's an overwhelming question. I think we've already become too big a field for anybody to say "This is the coolest" or "This is the greatest" right now ... unless somebody comes out with glass that walks and talks for you. There

DISCOUNT HYDROPONICS®

WE'RE GROWING...COME GROW WITH US!

**One of the Largest
Hydroponic Stores
in the USA!**

- Lowest Prices
Guaranteed!
- Discreet Packaging
- Largest Inventory

- Confidential
Transactions
- We are the Mail Order
Professionals!

FRANCHISE OPPORTUNITIES AVAILABLE! 877-GROW-IT-7

3 LOCATIONS TO SERVE YOU!

DISCOUNT HYDROPONICS OF RIVERSIDE
4745 Hiers Ave.
Riverside, CA 92505
951-689-4575

DISCOUNT HYDROPONICS OF SAN MARCOS
330 Rancheros Drive, Suite 124
San Marcos, CA 92069
760-798-4214

DISCOUNT HYDROPONICS OF PALM SPRINGS
1251 Montalvo Way, Suite H
Palm Springs, CA 92262
760-424-8292

WWW.DISCOUNT-HYDRO.COM

HyperLogic
Commercial Water Filtration

STATUS HOURS TEMPERATURE
 RUN 5.7 400 73°F
 PRODUCT PPM FEED PPM % REJECTION
 98.8%

ALARM
MUTE/RESET

POWER
RUN/STANDBY

HyperLogic
Commercial Water Filtration
REVERSE OSMOSIS SYSTEM CONTROLLER

CONCENTRATE RUN
 BASIC RUN
 PURIFIED RUN

FOLLOW THE
H I P E

www.hyper-logic.com

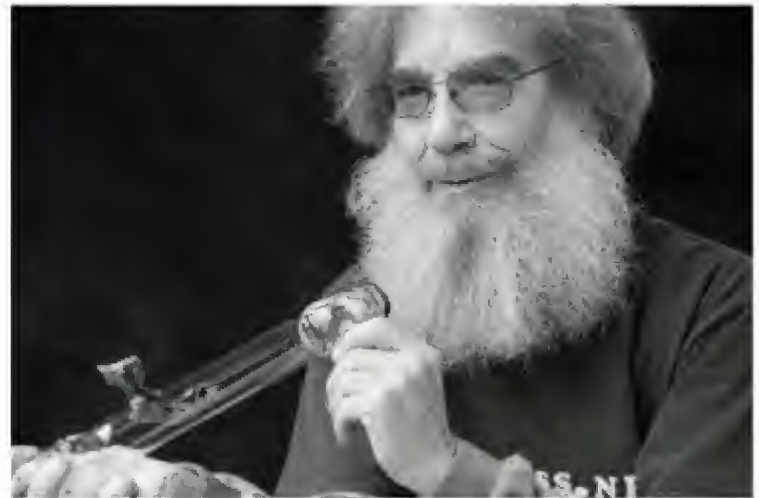

Bob has embraced the word: "co-oper-tition."

are good artists on both coasts. The Northwest seems to pull a lot more, though. From Bellingham—shoot!—from Smokey Point down, I've been to studios and ... I'm just really hard-pressed to say what's the best or who's the best. Everybody's got a little edge.

There's a lot of beautiful work out there. Be your own judge—I don't want to judge for somebody.

What bit of advice would you like to pass on to the entire smoking culture?

Oh ... tilt your pipe 90 degrees; the flame should go straight up. Turn the pipe sideways—that would be good.

As far as artists who are starting out, read a few books, take a couple classes from people they think are really good, and be patient. Make quality work; don't try to "produce." Let it flow, let it flow—make a product that matches your skills, and your skills will improve; the more complicated pieces will come along. Like playing a musical instrument—the more you practice, the better you get. At least you hope so.

What do you think your legacy will be?

Here's a new word I heard on television: *co-oper-tition*. That's a good one. The more we cooperate, the more we compete, the better we're

going to produce things. So co-oper-tition! That's my legacy.

There was a story you told years ago about why and how these pipes come out of you. You said maybe you're channeling them, that maybe they could be used as the key to a spaceship.

I did say that. Sometimes I feel like I'm channeling energy and I'm producing the keys to the spaceship. Isn't that cool?

Tell us how you became a teacher.

After stumbling on fuming, I researched and found no mention of it in any of the references I could find. Here I was, fuming and adding layers of clear glass and melting it down and building it up and melting it down and producing pictures with lines and dots and precious metals. And this new style produced beautiful effects—especially when you smoked out of it; it appeared to change the color of the glass. I was truly impressed. I said to myself, "This technique will raise the bar on lampworking." And that's when I decided to learn all I could and teach. Over the years, I've taken classes on health and safety, equipment, even speech classes, to better impart what I know in this field to whoever I'm teaching. That's it. ✨



The Best Just Got Better

NEXT GENERATION LED GROW LIGHTS



NEW SOLARSTORM 880

25% MORE LIGHT
Than Previous Models

UNIVERSAL VOLTAGE
Compatible With 90-277 VAC



NEW SOLARSTORM 440

BEST POTENCY
Exclusive UVB Lights on 880/440
Selectable Bloom/Veg Spectrum



NEW SOLARFLARE 220
NEW SOLARFLARE 110

BEST RELIABILITY
Made In California
3 Year Full Replacement Warranty



 **GrowersHouse.com**

WORLDWIDE SHIPPING AVAILABLE



*Special Exclusive Pricing & FREE Light Hangers
for High Times Readers*

Call Us and Mention Code: CLWHIGH

ORDER ONLINE OR CALL 1.855.289.1441

Vertical HydroGarden



Let Vertical HydroGarden Handle All Your Gardening and Potting Needs!

HUGE SELECTION OF SEEDLINGS, VEGETABLES & HERBS

THE EXPERTS IN GRO FACILITIES

- Modular Systems
- Commercial Systems
- Vertical Systems
- Hydroponic Systems
- Aeroponics Systems
- Aquaponic Systems
- Gro Classes

Introducing

CUSTOM MODULAR INDOOR GROW ROOMS

We offer grow rooms in any size that turns ANY room into a Professional Grow Room.

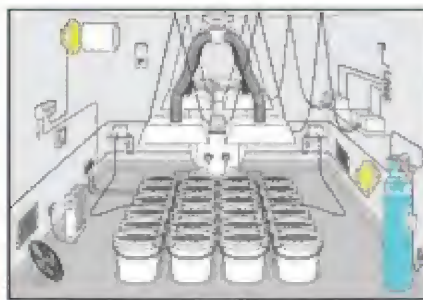

MODULAR GRO ROOMS • DESIGN CONSULTING GREENHOUSES • MANAGEMENT & STAFFING TRAINING

(714) 367-6538

Verticalhydrogarden.com



Cultivation Clinic

Using trellises to get the most out of your grow.
Story & Photos by Nico Escondido



Trellising 101

After writing at length about the myriad grow systems (see p. 64) available on the market today, I figured I'd throw out a more advanced concept to aid you in maximizing your system of choice. Trellising is an excellent cultivation technique that not only helps to develop strong, healthy plants but can also increase your yields significantly. This can be a huge plus for indoor or home growers dealing with limited space and/or plant counts, who'd like to make it from one harvest to the next without having to hit the road to find some extra stash.

Simply put, trellising relies on a system of latticework that supports and directs growth in a manner that allows plants to deliver on their potential. The support comes directly from the physical framework of the trellis, while the direction comes from you, the grower.

The latticework can take on many forms. Some trellising works vertically, while others work horizontally. Vertical trellising most often uses a solid frame of wood, metal or bamboo rods with interconnecting pieces that run horizontally



From top: An indoor net-trellis system covering the entire garden canopy; vertical trellising in an outdoor garden using 4" square steel mesh placed around each plant during vegetation.

around and through the framing. These horizontal connections may be solid, or they may be made of softer material, such as strings or wiring. Vertical trellising is generally installed at each individual plant site and must be done in the early stages of growth so as not to interfere with plant or root development later on.

Horizontal trellises usually have a much softer feel and can be used in gardens ranging from just a few plants to large-scale grow operations. Horizontal trellises require some vertical support, which can come in the form of walls, poles at the garden corners, or even suspension from a ceiling. Most horizontal

trellises use netting or wide-hole screens that are installed over the garden canopy when the plants are still in their vegetative stage, allowing them to grow up through the lattices.

Whether you're going the vertical or horizontal route, once the trellis is constructed, the rest of the process will be the same. As plants grow, their branches are pulled through the trellis to train the plant to grow in the desired direction. The goal is to separate the branches and thick, lush growth so that light can more easily penetrate the garden canopy. It is also important to deploy smart pruning techniques to aid in plant development. Tricks such as topping or pinching off the plant release excess hormones that result in additional lower shoots developing directly under the cut. These new shoots usually grow quite vigorously and can benefit enormously from trellising.

Stay tuned for next month's column, where we'll dive deeper into pruning techniques, with tips and tricks for increasing yields while maintaining your plants' potential potency. ✨

Featured Strain of the Month: Blue Dream, 19.03% THC

Blue Dream has been around for a few years now, but her popularity keeps growing as marijuana becomes more mainstream by the day. Aside from winning numerous accolades at our Cannabis Cups, both for flowers and hash (she happens to produce excellent concentrates, by the way), Blue Dream is also a top seller at dispensaries across the US.

Known mostly for her distinctive *sativa* high and overwhelming flavor profile, Blue Dream is a connoisseur's ... well, dream. A *sativa*-dominant hybrid, she's the offspring of Blueberry and Haze parents. Most cannabis cognoscenti believe that Super Silver Haze was the Haze parent, while some maintain that it was Strawberry Cough (which is only half-Haze, but this

argument seems to make sense after smoking Blue Dream, which is fairly reminiscent of the Cough in both flavor and high).

From a grower's standpoint, Blue Dream is a very good yielder and does well in hydroponic grows. She also responds well to "sea of green" (SOG) formats, which some Haze hybrids have trouble with. Organic nutrient programs tend to bring out the best in Blue Dream, both in terms of flavor and potency, as evidenced by the 19 percent THC mark that she hit at the 2012 Los Angeles Cup, in an entry grown by American Organic.



Thanks for reading, everyone, and remember, grow ... and help the world grow, too!



LARGEST INVENTORY, LOWEST PRICES. DISCRETE SAME DAY SHIPPING.

GROW LIGHTS

HID Complete Grow Light MH/HP5 System with Wing Reflector

600w - ITEM H600HCBW
1000w - ITEM H1000HCBW
\$209.99



400w Complete Electronic Grow Light

MH/HP5 System with Wing Reflector
ITEM H400EBW
\$179.99



EXTRACTION KITS



ITEM V5G4BK - \$21.99
ITEM V5G3BK - \$24.99
ITEM V5G8BK - \$69.99

DRY NETS



ITEM VDN22
ITEM VDRY200
\$32.99

	Organic Complete	Hydroponic Complete
2'x2'x4'	\$399.99	\$499.99
2'x4'x6.5'	\$599.99	\$849.99
3'x3'x6.7'	\$659.99	\$899.99
4'x4'x7'	\$699.99	\$949.99
4'x8'x7'	\$1,249.99	\$1849.99

HYDROWHOLESALE.COM

1.866.803.2100

Monday - Friday: 10 a.m. - 6 p.m. EST
Saturday: 12 noon - 6 p.m. EST

COMPLETE GROW ROOMS INCLUDE:

- Grow Room
- Carbon Filter and Fan Combo
- Light System
- Timer
- HVAC Tape
- Fan
- Hydrometer Thermometer
- Complete Hydroponic System with Reservoir, Pump, Timer, Pots, Tray and Stand
- A How-To Instructional CD



HYDROWHOLESALE.COM

GROW IN THE ROUND

STARTING AT
\$495

DON'T BE SQUARE

BY
HYDROPONICS
GROUP.COM

Intercooled Cool Tube
400w or 600w

GROW MORE
FOR LESS

Vents

Tent is 6ft tall
3ft across



Scientifically designed
for better air
flow

Maximizes space
and efficiency

Round,
no light loss
in corners

Light tight

Better light dispersion
for bigger plants
and higher yields

Cooling Fan



NEW!

THE GROW TUBE

ANOTHER ENGINEERING MARVEL FROM HG

Base system

Options

- Tent
- Soil pots or hydro tub
- Rope hangers
- Ducting
- 400 watt MH / HPS
- Cool tube w/ intercooler
- Basic nutes

- Raptor odor controller
- CO2 pads
- Pro nutrient packages
- 300 watt LED setup
- 600 watt MH / HPS
- Lighting schedule
- Dutch Master nutrients

Comes with Lifetime Support

NO ONE BEATS OUR VALUE TO YIELD RATIO!

Get in the Game CALL NOW!

800 850 6360

www.HydroponicsGroup.com



MAD HATTER

NUTRIENTS & SOILS



WWW.MADHATTERNUTRIENTS.COM

Expert Grow Advice

Fading leaves, bad fertilizers, feminized versus regular seeds, the best time to harvest and more ...

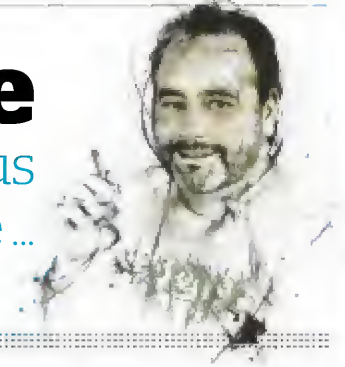

Send your cannabis cultivation questions to @deardanko or deardanko@hightimes.com.

This close-up of Cloud 9 from Dinafem Seeds shows glandular trichomes that are still mostly clear.

SUBJECT: Ripe for Harvest?

FROM: Kron Burgundy

🌿 When checking with a microscope for ripeness, should you check multiple sites on the same plant? Or can you get all the info you need from a nice top cola?

Dear Kron,
It's a good idea to check various parts of the plant if you plan on harvesting all at

once. Because the top buds ripen more quickly, you can clip them off first and then let the lower branches continue to finish flowering. If you can't stagger your harvest this way, use the microscope to examine the glandular trichomes. For most growers, the point when the majority of trichomes have gone from clear to cloudy but have not turned amber is the best time to harvest. However, some growers prefer to let many of the gland heads become amber for a more lethargic, stony effect.



COURTESY OF DINAPEM SEEDS

Danko Tip: To avoid mistaking a pH fluctuation for a nutrient deficiency, always check the pH levels of your nutrient solution and growing medium.



Fall colors can be seen as this Blue Widow plant nears harvest.

SUBJECT: **Leaf Fade Away**
FROM: **Terpene Cowboy**

🌱 I've taken your advice on flushing my plants and have been happy with the results, but I've noticed that the color of the leaves starts to fade and turn lighter, especially in the veins. Aren't these signs of a nutrient deficiency that I should be trying to avoid? Am I going overboard by flushing for a full two weeks?

Dear TC,
It's perfectly normal for your leaves to fade and turn fall colors such as yellow, pink, red and light purple. This is a sign that your flush is working and that you're successfully removing built-up nutrient salts. You're correct that these would be signs of a nutrient deficiency earlier in the plants' life, but the last two weeks of the flowering phase is a time to remove

nutrients, not add them. Your buds will burn and taste better, leaving behind only a wispy white ash. Unflushed pot burns like charcoal, always needs to be relit and leaves a dark, chunky ash.

SUBJECT: **Start Me Up**
FROM: **Michael**

🌱 Hey, man! I'm looking to start a closet grow. I'm a beginner at growing and was hoping you could give me some tips as to what kind of setup I should use. Here are a few things I would like your opinion on (and if I missed anything important, please let me know): Hydro or soil? Growbox or grow tent? (I can't have any smells leaking out of the closet.) Also, are there any strains that are genetically specific for indoor and/or closet growing? And what should I expect to spend on a good setup? Thanks in advance—I really appreciate the help!

Dear Michael,

My advice to most beginners is to start with soil, or more accurately the kind of soilless mix typically sold in bales or bags. As for containers, 3- to 5-gallon pots will let you raise decent-sized plants that you can hand-water with a nutrient solution. This type of growing is more forgiving for the beginner than the more complicated automated hydroponic systems. Also, if your budget doesn't allow you to purchase a growbox, buy a good grow tent instead: They're much cheaper as well as easy to set up (and take down).

Put a significant amount of your budget toward lighting, airflow and odor control. If you dedicate your funds to these issues now, you won't have to scramble to fix them later. Use a high-intensity discharge (HID) light—a 400- or 600-watt bulb is perfect for a 4' x 4' grow tent—and hang it securely so that you can lower or raise it as your plants grow. Use a vent fan with an activated-charcoal can filter attached, and place a recirculating fan in the tent to keep the air moving.

Start with an *indica*-dominant hybrid that won't stretch out or take forever to flower like some of the *sativas* out there. All in all, your total costs should be less than \$2,000 to get growing now. That may still be a hefty sum for a lot of people, but think of it as an investment in your future, knowing that you'll be producing your own pot for pennies on the dollar—and you'll also know everything that went into it (or onto it).

SUBJECT: **Just Say No to Miracle-Gro**
FROM: **Timothy M.**

🌱 Is Miracle-Gro a good source of nutrients for my vegetating pants? And should I use 1 gallon of mixed nutes per plant?

Dear TM,
I absolutely wouldn't recommend using Miracle-Gro to grow marijuana (or anything else, for that matter). Not only is it made from chemicals formulated in a laboratory, but the company that produces it—Scotts—has formed a business partnership with Monsanto to sell us Roundup, Ortho and just about any other toxic chemical sludge they can derive. These are also the same people genetically modifying and patenting seeds.



CROPTOPSGREENHOUSES.COM

PORTABLE GREENHOUSE
95% RECYCLABLE
RUST RESISTANT

**Put your crop on top with
Crop Tops Instant Greenhouses!**

**NOR CAL'S PREMIER PLANT
SAVING NECESSITY**

**LIKE US ON FACEBOOK TO
WIN CANNABIS CUP TICKETS**



**NO MORE MUD BUD.
NO MORE BREAKS**

**PROTECT
YOUR
CROP**

- START YOUR STRAINS EARLIER FOR BETTER RESULTS

BIGGER AND BETTER BUDS

- STRONG TELESCOPING POLE GROWS WITH PLANT
- SAVE TIME & MONEY. NO MORE STORM DAMAGE
- CONVENIENT, LIGHTWEIGHT CARRYING CASE
- GOOD FOR QUARANTINE, DISEASE CONTROL, POLLINATION AND SO MUCH MORE!



CROP TOPS GREENHOUSES
info@CropTopsGreenhouses.com
530.274.8677
Facebook.com/CropTops.NorCal
www.CropTopsGreenhouses.com

NATURE'S NECTAR
Keep it simple.
CERTIFIED ORGANIC EARTH FRIENDLY
PREMIUM PLANT NUTRIENTS

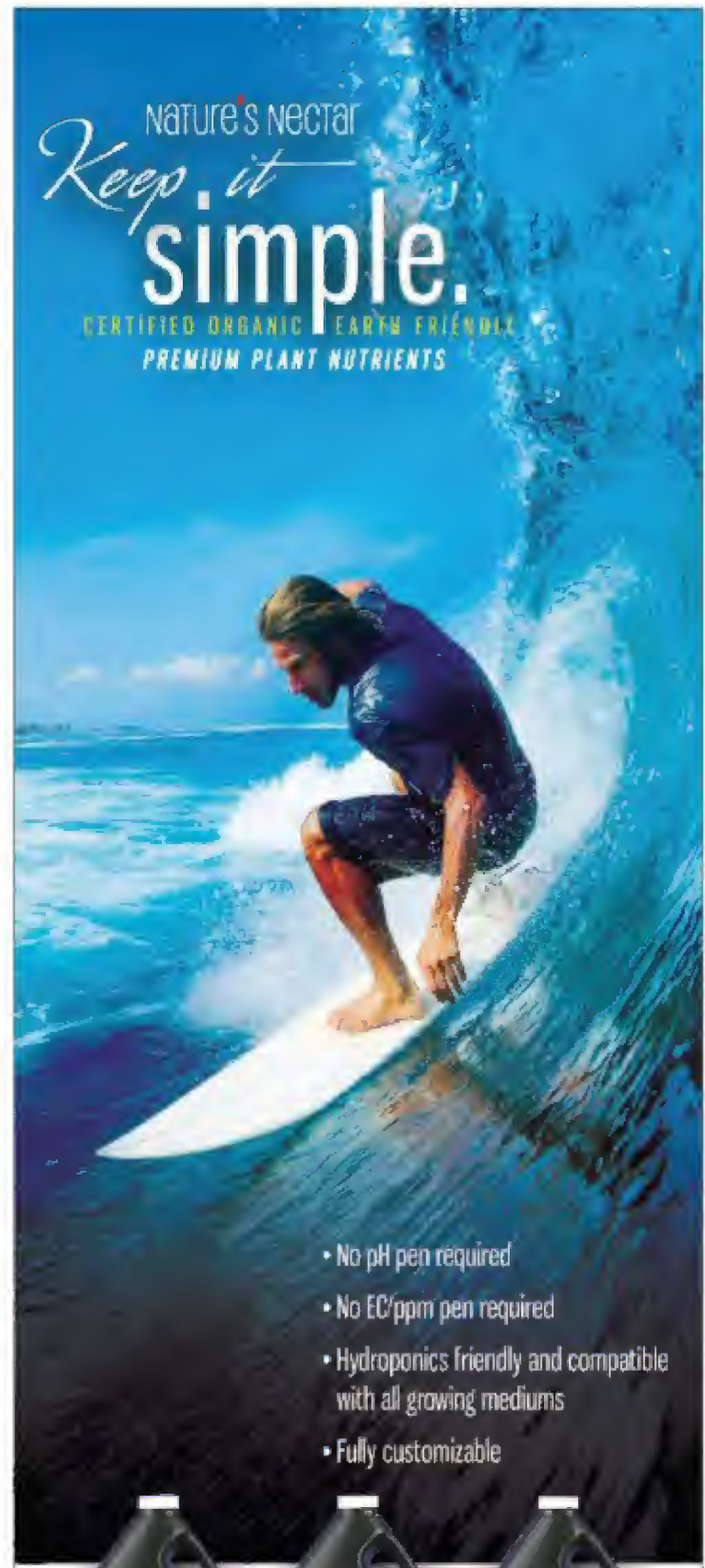

- No pH pen required
- No EC/ppm pen required
- Hydroponics friendly and compatible with all growing mediums
- Fully customizable



Pro-Cert
APPROVED INPUT



www.ez-gro.com

Snow Cap

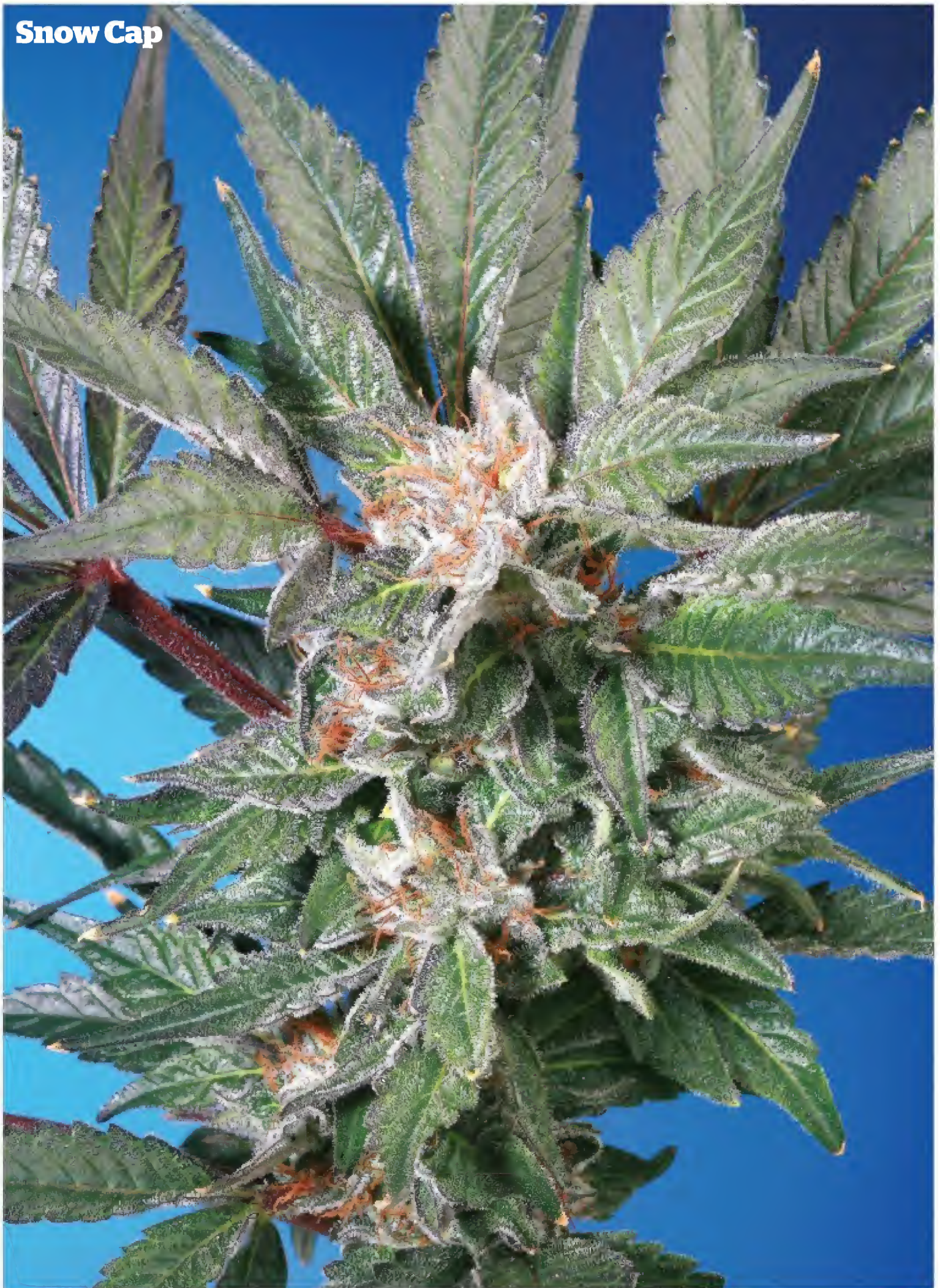



VAPORNATION

YOUR ONLINE VAPORIZER SUPERSTORE



KANDYPENS
SKYCLOUD

VAPORIZER SOLO



GET 15% OFF WITH COUPON CODE:
HIGHTIMES
WWW.VAPORNATION.COM

TEL: 888.321.VAPOR (8276)

Danko Tip: Take careful notes on all your growing experiences in order to profit from your mistakes as well as successes.

Inventors of prize winning systems



POLLINATOR
The home of homemade hash since 1994

Bubbleator
The quickest route from trash to stash!



Get ready Start your run 5 minutes later

Create prize worthy resin using the original Amsterdam

Pollinator Company
Nieuwe Herengracht 25
1011 RL Amsterdam
The Netherlands
[t] +31-20-4708889
[f] +31-20-4715242
[w] www.pollinator.nl
[e] info@pollinator.nl



Ice-O-Lator Pollinator



Plants grown under full sun in natural soil exhibit total terpene production.

Plants don't need these poisons, and neither does our environment. A Google search is all you need to discover the numerous crimes against humanity and our planet committed by these companies.

Instead, get yourself some nutrients made from natural ingredients, such as kelp (seaweed), bat and seabird guanos, liquid fish, or any of the other plentiful options for feeding your plants a proper diet of healthy food. The closer we get back to nature, the better our pot will taste and burn, and the better off our planet will be as well.



916-519-7649
FREE SHIPPING
IN THE CONTINENTAL U.S.

CaliExtractions.Com

AIRCRAFT ALUMINUM & 316L STAINLESS STEEL



200g 900g 300g

ADDITIONAL SIZES AVAILABLE ONLINE



caliextractions@gmail.com
CaliExtractions.com

SUBJECT: **Feminized or Regular Seeds?**

FROM: **Jake the Muss**

🌱 If you were starting a grow op and had to choose between feminized and regular seeds, which would you choose (and why)? Also, what are the disadvantages of feminized seeds?

Dear Jake,
My preference is always to grow from regular seeds. In my experience, you'll get hardier and more potent plants that way, assuming the seeds have been purchased from a reputable seed bank. If we're talking about a sizable grow op (as opposed to a growbox, tent or closet grow), then you should definitely grow from clones taken from a mother plant that was grown from regular seeds.

The key to achieving this is to grow out plants from regular seeds in order to select a mother plant. To determine the sex of your chosen plants, you must take a clone from each one and then flower the clone. This way, you'll know the sex and traits of each plant's corresponding "parent" without having to flower the potential mother plant herself.

Pick the strongest female from the clones you've flowered and then discard the males and unchosen females. Your vegging female mother plant is now ready to take clones from in order to fill your grow op. The benefits of this method are that the plants will all behave the same way during the grow cycle, with a level canopy that you won't get growing from seeds.

The disadvantages of growing from feminized seeds are

DON'T LET YOUR JOB GO UP IN SMOKE!

KEEP IT UP!

OHHHH YEEAH!

NO WIMPS HERE!

Beware the WIMPINATOR!

C'MON... GET SERIOUS, OMAR!

THE FUTURE IS YOURS... ISN'T IT? (IN YOUR HANDS!)

DON'T MISS IT!

Everything You KNOW is WRONG!

NO WIMPS ALLOWED!

Shake it like Ya mean it!

FIGHT APATHY... OR DON'T

WHY ARE YOU LOOKIN DOWN HERE?

MONKEY DONG

MONKEY WHIZZ

MONKEY FLASK



The Finest Strap-On Urinating Device Available!

only \$79.95!

The World's Best Selling "Urine Substitution Kit!"



only \$39.95!

The Most Discreetly Concealed Bottle!



only \$24.95!



SAME DAY SHIPPING
ALL MAJOR CREDIT CARDS ACCEPTED
BEST PRODUCT! CHEAPEST PRICE!
SATISFACTION GUARANTEED!

1-800-936-1070
SERIOUSMONKEYBIZZ.COM



www.monkeybizz.com

Why?



not so serious

Why not?

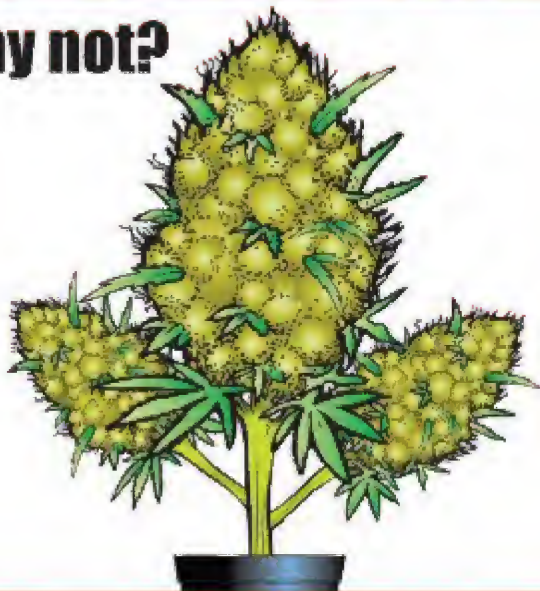

Get Serious

ACQUISITION OF LIVE CANNABIS SEEDS IS ILLEGAL IN THE UNITED STATES
PAYABLE IN US DOLLARS FROM ANYWHERE IN THE WORLD.

20 years Since 1994

Serious Seeds

www.seriousseeds.com

Danko Tip: Secure a waterproof tarp under your hydroponic reservoir to avoid flooding in case of leaks or pump failures.



Regular seeds are preferable to feminized ones for creating mother plants.

that you can only grow them out once, and the plants lack the vigor of those grown from regular seeds. The big advantage is that you don't have to cull the males, since you're guaranteed females. However, feminized seeds are also more prone to hermaphroditism, so you have to keep a close eye on them.

SUBJECT: **Tent Lighting**

FROM **Sunikom**

🌱 In a 4' x 8' grow tent, would you rather go with 400-watt induction lighting, or 600- or 1,000-watt high-pressure sodium (HPS) lights—and also, how many lights? I recently came across induction lighting. I've read about it on so many forums, but the lights are getting mixed reviews. I'm iffy about them: Some seem to produce and some don't. I want to know the real deal.

Dear Sunikom,

My advice at this stage is to use two 400- or 600-watt HPS lights for a 4' x 8' grow tent. The best I've seen are the Philips ePapillon versions that I recently wrote about in my article "The Indoor Acre" (Aug. '14). As for induction lighting, the quality of the technology is still up for debate. I haven't seen anything to sway me from believing that HID lights such as HPS and MH (metal halide) are the best for growing cannabis indoors.

If you think you can handle the extra heat from the 600-watt lights, then I would certainly go with them over the 400-watt versions, since you'll get bigger buds for sure. You could also place two 1,000-watt lights in there, but you're going to need some serious airflow and cooling to keep from overheating and burning your plants in that enclosed space. 🌱

Celebrating 40 Years in Business!

EZ Gro Mushroomkit

The EZ Gro Mushroomkit is the easiest way to grow your own mushrooms...



Only TWO EASY steps

1. Mix the grain and Psilocybe Cubensis spores together without ever having to open the sterilized bag.
2. Once the grain has been colonized, mix it with the bag of compost.

That's all there is to it!

- Put the kit in a warm place
- Wait a couple of weeks for your mushrooms to start growing.
- No need to water it or even look at it.
- Just go away and leave it alone
- The mushrooms grow automatically.

It's that simple!

We include:

- Complete instructions with color photos

PLUS:

- A free DVD shows everything you need to know
- Awesome videos of mushroom farms in Holland



The EZ Gro Mushroomkit

Includes everything you need:

- Psilocybe Cubensis spores
- Grain bag
- Our world famous blend of Kow-A-Nite Compost in its own filtered growbag.

EZ Grow Mushroomkit Just \$135

[price includes shipping]

For more photos visit www.Facebook.com/HomesteadBookCompany

HOMESTEAD

BOOK COMPANY

P.O. Box 17444, Seattle, WA 98127

- EZ Gro MushroomKit. \$135**
2-step grow-it-yourself kit includes Psilocybe cubensis spores and shipping. Sorry, not sold outside the USA.
- The Mushroom Cultivator \$40**
The biggest and best book ever published on growing mushrooms, 400 pages,color photos.

Order Toll-Free at 800-426-6777 or online at www.homesteadbook.com/mushroomkit or mail a check or money order to PO Box 17444, Seattle WA 98127.

Checks take longer to process than money orders. Sorry, no COD.

Name _____

Address _____ Apt. _____

City _____ State _____ Zip _____

Email (optional) _____

Washington State residents please add 9.5% sales tax. Total Enclosed _____



DISCOVER IF MARIJUANA IS RIGHT FOR YOU

Visit www.SaferThanSmoking.com to pick up your Marijuana Doctors Kind Pen. Use promo code MMJDoctors at the time of checkout for an exclusive discount.

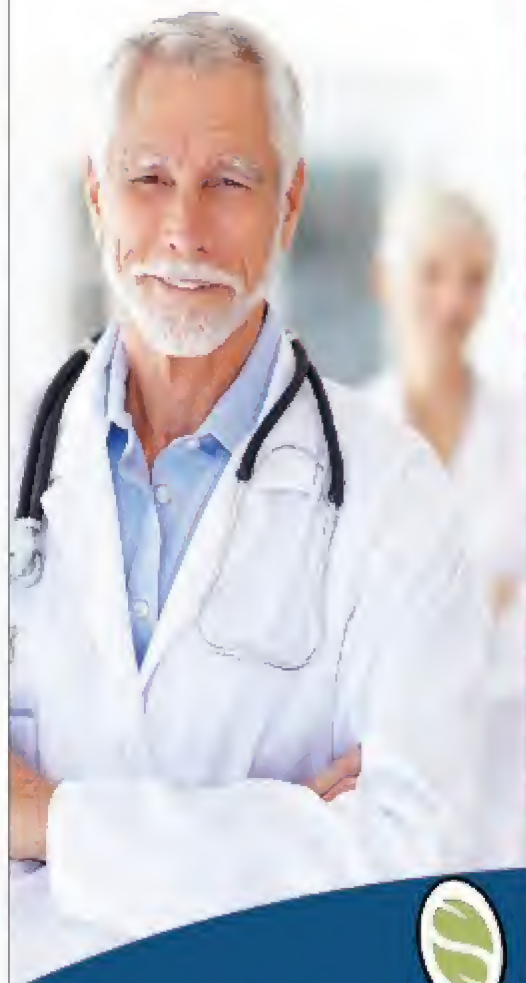

The Kind Pen®

Personal Vaporizer Pen
OIL / WAX / HERB
LIFETIME WARRANTY

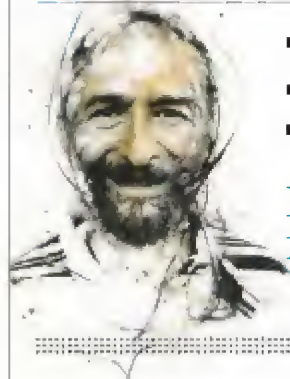

Heart of the Matter

Female tokers, “hempline,” fun flicks and vaping.

Got a question for Dr. Mitch? Email him at 420research@gmail.com.

Are women more sensitive to the plant's effects than men?

Viv LA Difference

Hi Viv,
Generally, yes. In one study, women and men—matched for how much they usually smoked—were given a standard dose in the laboratory. The women gave the plant higher ratings for potency as well as for how much they'd like to use it again. That being said, the women did tend to be smaller in terms of body size, which might have contributed. Nevertheless, especially for women, less might very well be more.

Why aren't we using hemp to make fuel more often?

Bo String

Hi Bo,
Haven't you heard? Growing hemp is illegal in the US (though these days, a number of states are being allowed to grow it for research purposes). We could make “hempline” or use it as one of many plants for biodiesel, but given our current laws, it's cheaper to use grains, kitchen waste or seeds.

What's the first flick to show marijuana use?

Jake

Hi Jake,
I'd bet on the 1924 silent film *Notch Number One*, which was re-released as *High on the Range*. In it, legendary stuntman Yakima Canutt smokes a joint after work,



despite silent-screen star Ben F. Wilson's warning that it'll make him go “bughouse loco.” Of course, he ends up killing a cowhand as a result. You can catch a clip from it in Ron Mann's documentary *Grass*. Canutt went on to direct the stellar chariot-race sequence in *Ben Hur*.

Why don't more people use vaporizers?

Stan Steamer

Hi Stan,
Research suggests a few common gripes. Some folks think the vaporizer takes too long to warm up or just presents too much trouble to use. As a result, many people who don't have respiratory symptoms like wheezing or coughing don't see a reason to bother. But the new technology sidesteps these problems, and preventing respiratory symptoms *is* a good reason to use these devices.

I also hear complaints about the effects taking longer to kick in. I need to gather some more data on this issue, but is waiting an extra 10 minutes really such a hardship? 🌿

Dr. Mitch Earleywine, PhD, is a professor of psychology at SUNY Albany and the author of Understanding Marijuana and The Parents' Guide to Marijuana.

GOOD DOG

(Queso Negro x Pakistani)

Exclusively from Dr. Greenthumb

ACQUISITION OF LIVE CANNABIS SEEDS IS ILLEGAL IN THE UNITED STATES
PAYABLE IN US DOLLARS FROM ANYWHERE IN THE WORLD.



Customer grown and photographed by Turbine2

ORDERING / INFO DESK

1.613.330.2404

For a catalog including a \$10 off coupon send \$5 to;

"RWJ GENTECH INC." Box 37085
Ottawa, ONTARIO, K1V 0W9 CANADA

www.drgreenthumb.com

What's in a Name?

Let's be specific—and accurate—when we talk about BHO. *By Josh Shipman*

We've all heard the many terms for BHO—shatter, earwax, budder, crumble, taffy, honey oil—and if you've been dabbing for a while now, you probably have your favorite form. Perhaps you prefer earwax or crumble because it's easier to work with. Or maybe shatter is your dab of choice because of its clarity and smooth texture.

While these slang terms have their purpose in the industry, they give consumers only a vague idea of the processes used and the quality of the product in the end. The good news is that BHO extractors are relying on scientific approaches and looking to the essential-oils industry for insights and language to help them produce the highest-quality extracts, and communicate that information to the consumer.

The essential-oils industry has been using solvents in extractions for decades—and as a result, it's created a dictionary of terms that can cross over to the cannabis industry. The three terms I'd like to introduce are *concrete*, *oleoresin* and *absolute*. These terms identify the three types of products most extractors produce.

A concrete is produced from fresh plant material, whereas an oleoresin—the most common type of BHO found on the market—is produced from dry material. An absolute, on the other hand, is created when a concrete or oleoresin is further refined with alcohol, removing unwanted waxes and lipids.

Concretes are a true representation of the original raw material used in the extraction. They're often very harsh, because most of the volatile terpenes have been preserved. An oleoresin is a better representation of the “cured” product, since it's been dried and has lost some of those terpenes,

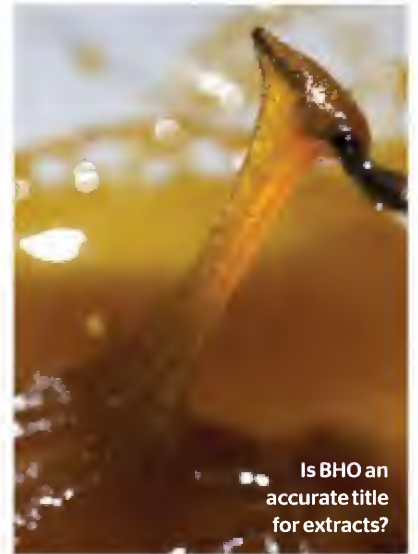

Is BHO an accurate title for extracts?

while developing others. An absolute is considered the cleanest of the three because the final product has been taken through an extra process to remove waxes, which makes for a more potent and arguably smoother dab. Creating an absolute requires more time and skill, though, so expect to pay more for these extracts.

With the crossover of this language into the cannabis industry, it's been suggested by more than a few producers that BHO (an abbreviation for “butane hash oil”) isn't an accurate title for these extracts, since oil is *not* a desirable end product.

Since oleoresins are the most common form of extract being produced, perhaps the name should be updated to “butane hash oleoresin.” For those refined, more expensive absolutes, BHA might be a more accurate title as well.

On second thought, maybe not: BHA is the abbreviation for a cancer-causing preservative found in processed foods. *Our* BHA is actually cancer-killing! ✨

Josh Shipman is Fremont County Cannabis's resident greenhouse grower, specializing in organic horticulture and with a background in writing and research.

It's Organic*, It's Effective, **It's Safer® Brand.**
OMRI® Listed insecticides, fungicides and herbicides.

www.saferbrand.com/hydroponics

*for use in Organic Production



ONTARIO SEED BANK

YOUR SOURCE FOR THE STRONGEST NORTH AMERICAN STRAINS



CHECK OUT THE TRUE ORIGINALS AT
ONTARIOSEEDBANK.CA

ONTARIO'S BEST SEED COMPANY®
EXCLUSIVE RETAILER



green giant seeds



SHOP IN PERSON IN A SAFE ENVIRONMENT



416-255-5355

3351 Lake Shore Blvd W - Toronto, ON M8W 1N1
MON to SAT 10am - 5pm | SUN 10am - 3pm

DANK DELIVERY LINE 416-255-9333 **FREE DELIVERY ON ORDERS OVER \$25**

TO ALL COMPUTER TROUS + WANNABES

Canadian owned and operated.

Directions: Take QEW Toronto to Cawthra Rd exit, then south on Cawthra to Lakeshore Blvd. Go east on Lake Shore Blvd for 5 miles. Look out for the neon '420' sign on the south side of the street.



ACQUISITION OF LIVE CANNABIS SEEDS IS ILLEGAL IN THE UNITED STATES | PAYABLE IN US DOLLARS FROM ANYWHERE IN THE WORLD

LUMEPower



1000W Fan P Style Ballast
Low as \$120.00



1000W Nano Style S Fan Ballast
Low as \$110.00



1000W Non Fan N Sealed Ballast
Low as \$135.00

www.lumepower.com

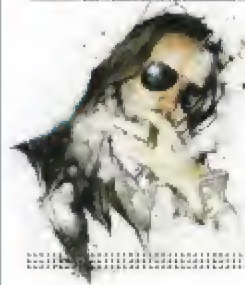

The High Cost of Activism

A family flees police harassment in Texas.

Anyone who's been to the Lone Star State knows that its unofficial motto, "Don't mess with Texas," is no joke—especially to the cops there. But what happens when the law in Texas messes with *you*? That was the frightening situation faced by my dread-headed activist pal Minister Mike, his lady Shoreline Sheena and their young son this past April after their trip to the U.S. Cannabis Cup in Denver.

The couple had just had the time of their lives and had even gotten engaged at the Cup. But shortly after returning to their hometown of Copperas Cove, two plainclothes officers approached Sheena asking to search their house, claiming they'd heard that the pair had brought marijuana home with them. How did the authorities know they'd just returned from Colorado? Most likely by monitoring their Facebook pages (one of the officers had even attempted to add Sheena as a friend weeks earlier). As an activist and Army veteran, Sheena knew her rights and refused. The police left—but not before threatening to return with a warrant and some agents from Child Protective Services.

Several days later, neighbors reported seeing the police and CPS poking around a shed in Mike and Sheena's yard. According to Mike, these incidents were just the latest in an escalating campaign of harassment. Months earlier, they'd been given an unusually hard time while trying to establish a community vegetable garden in their neighborhood. Initially, they'd encountered no problems and were

close to finalizing the permits. But after officials met them in person and saw their dreadlocks, their permits were suddenly denied. They were even accused of plotting to grow marijuana in the proposed garden.

Realizing that this harassment would only get worse, the couple felt they had no choice but to leave the home that Mike had lived in his entire life. The next day, they loaded whatever they could into their Prius and headed back to Colorado.

Sadly, though, their hardships were just beginning. After arriving in town, their family car was totaled by an uninsured driver who was driving while

talking on her cell phone. Setting his family up at a friend's house, Mike rented a U-Haul and headed back for the rest of their belongings. When he returned to Copperas Cove, he found that his pets (which were being looked after by his mom) had been seized by officers from Animal Control under trumped-up accusations of abuse. Then, as he finished packing, Mike was again visited by the police—this time under the bogus pretense of anonymous reports of domestic violence. After he explained to the officers that he was there alone, they finally left—and so did Mike.

Mike and Sheena are now safely settled in Colorado, where they've gotten married and are rebuilding their lives. Had it not been for the generous donations from fellow activists and friends, they would never have been able to pull off their tumultuous transplant. If you'd like to help, go to gofundme.com/8u5ysc. ✨

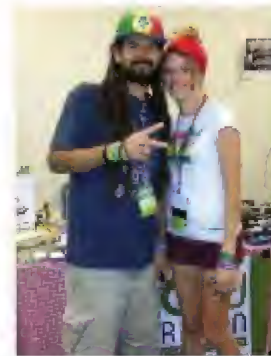

Mike and Sheena represent at the 2014 DFW NORML conference.

The Enhancer

"Perfect for your personal garden."

• Just Add Water & Shake
• Slows The Release OF CO₂ At Night
• Emits No Heat



TNB
1.888.543.8988
tnbnaturals.com

"Restock or get started now!"



AVAILABLE IN 32 TASTY PUFFIN FLAVORS!



NEW
Flavors



\$25 for 6 DROPPER bottles

**JUST A FEW DROPS
FLAVORS ANYTHING!**

Can be used with: Pipe tobacco,
Cigars, Favorite legal herbs,
Blunt wraps, Water pipes, Hookahs,
Vaporizers and E-cigarettes

1 oz spray bottles

available in all 32 flavors \$9.95 each



www.TastyPuff.com



How Washington Won

Evergreen should inspire us all to take action.

Allen St. Pierre is the executive director of NORML. Visit norml.org.



Rick Steves fires up the crowd in *Evergreen*.

If there's someone in America who's watched more cannabis-related documentaries than me, I sorely want to meet them. Frankly, most of these have been unwatchable, low-quality polemics. Many others are dated, serviceable only for the brief period of time they were conceived and broadcast. Few are gems for the ages.

I recommend *Evergreen: The Road to Legalization* to all *High Times* readers: It's an outstanding chronicle of Washington State's successful cannabis legalization campaign, worthy of every stoner's home library. The filmmakers enjoyed unfettered access to the behind-the-scenes efforts of the New Approach Washington campaign for nearly a year,

providing the viewer with an enthralling David vs. Goliath narrative: Activists finally win a legalization ballot initiative, and the behemoth of national cannabis prohibition begins to fall.

Alison Holcomb is the central figure in *Evergreen*. She's a NORML legal committee member and heads the criminal-justice department of the Washington State Civil Liberties Union. We see the brilliant organizational and communication skills of the kick-ass staff, but it's Holcomb's stunning ability to assemble a mainstream group of anti-prohibitionists as the face of the "Yes on I-502" campaign that anchors the film (and affirms the need, in my view, for more professional women to lead cannabis-law reform efforts).

Holcomb's two primary public sponsors of the legalization initiative were best-selling travel author and TV host Rick Steves (who also serves on NORML's board of directors) and Seattle City Attorney Peter Holmes—an *actual* sitting city attorney who served as a co-petitioner for the initiative. Holcomb and company quickly picked up major endorsements from politicians like Seattle's mayor, former federal prosecutors and judges, business leaders and the NAACP.

By this point, we all know how the legalization initiatives in Washington and Colorado turned out, but *Evergreen* is far from anticlimactic. The campaign created plenty of drama, but the traditional opponents—law enforcement, religious institutions, alcohol and pharmaceutical interests—didn't provide it. Instead, it was an insular group of medical marijuana vendors (and their lawyers) who sought to maintain a continued monopoly on selling unregulated, untaxed and prohibition-priced cannabis. Thankfully, this self-interested minority held no sway in Washington.

Following passage of the law in November 2012, police and prosecutors statewide halted the arrest and prosecution of cannabis consumers and released hundreds from jail who were awaiting trial for pot "crimes." This summer, Washington joined Colorado in its successful rollout of a retail cannabis industry. *Evergreen* manages to catch it all. 🌿

FREEDOM FIGHTER

New York State of Kind

Troy Smit works to make weed part of the Empire State.

After watching many people who were close to him suffer from conditions that could have been treated with medical marijuana, Troy Smit decided to become involved in the fight to reform the marijuana laws in New York State. "I saw the amazing

healing qualities of cannabis through friends and family who have MS, fibromyalgia, breast and brain cancer," Troy says.

"I saw that cannabis was no more dangerous than Advil or Red Bull. Most importantly, I saw that our cannabis policies in New York and the US hurt my friends and my family."

He volunteered with Empire State NORML in 2003 and earned a seat on



the chapter's board of directors. In 2011, Troy founded the Long Island sub-chapter of Empire State NORML and expanded NORML's presence in the region.

Over the six years of his activist career, Troy has met with numerous State Department officials and foreign diplomats through the United Nations International Visitor Leadership Program. The issues associated with our

nation's cannabis policies are often a topic of discussion. Most recently, Troy has been hard at work lobbying New York's elected officials in support of medical marijuana, meeting with dozens of legislators.

And Troy gets down in the trenches, too. He serves as both an organizer and director with the founding chapter of the Global Marijuana March in New York City, one of the oldest pro-pot events in the country.

By Erik Altieri, NORML communications coordinator

WHITE RHINO



trifecta

vaporizer

1 VAPORIZER. 3 CHOICES.
THE TRIFECTA BY WHITE RHINO IS THE PERFECT VAPORIZER FOR THOSE WHO WANT MORE THAN JUST ONE CHOICE. WITH THE ABILITY TO USE OIL, HERBS AND WAX YOU WILL NEVER HAVE TO MAKE A TOUGH DECISION AGAIN.



WHITERHINOPRODUCTS.COM | 855.803.8883



MEDICAL MARIJUANA DIRECTORY



BLACK SHEEP BEANS
2-140 King St. East Suite #407
Hamilton, ON, L8N-1B2

Northern California
Land for Sale !!

Starting from 10 acres and \$37,500
Some with springs.
EASY TERMS AVAILABLE!
Call 530-598-8480

420Novelties.com

Special Digital Collector's Issue!

HIGH TIMES

The First and Only Magazine Collected Into One Incredible Anniversary!

TO ORDER GO TO
hightimes.com/infamous100

CALIFORNIA

Alternate Natural Solutions Inc.

8477 Enterprise Dr.
Jamestown, CA 95327
(209) 352-6779
altnatsol.com
"Home of the 5 dollar gram"

Club Cannex

11004 Magnolia Ave.
Garden Grove, CA 92843
Phone: 562-200-1164
www.clubcannex.org
rudy@clubcannex.org
Compassionate, Understanding,
Servicing,
Honoring, Inspirational, Passionate

Coffee Shop Blue Sky

377 17th Street
Oakland, CA 94612
(510) 251-0690
Open 9am-8pm Mon-Sat,
10am-6pm Sunday
oaksterdamgiftshop.com

The Good Life

4316 Melrose Avenue
Los Angeles, CA 90029
(323) 522-3542
Open 7 days, 10AM-11PM
facebook.com/goodlifemelrose
Twitter Good Life Melrose
Also fresh fruits and vegetables.

Green Dragon Caregivers

7423 Van Nuys Blvd. Suite C
VanNuys, CA 91405
(818) 442-0054
greendragoncoop.com
edward@greendragoncoop.com

High Quiggle Healing Center

1532 East Broadway
Long Beach, CA 90802
Phone: (562) 951-3975
Fax: (562) 951-3902
weedmaps.com
"A circle of healing is never ending"

Love Shack

502 14th street
San Francisco, CA
(415) 552-5121
theloveshackcooperative.com
Mon-Sat 10am-7pm,
Sun 11am-4pm
Full Service Dispensary
Voted Best of The Bay

Mind, Body, and Soul Collective

3131 East Central Ave.
Fresno, CA 93725
Phone: (559)-486-6010
Fax: (559)-486-6011
mbscollective.com
admin@mbscollective.com
"Open 7 days a week--Quality,
Integrity, Trust"

1 Love Wellness Center

1841 El Camino Ave.
Sacramento, CA 95815
916-231-LOVE
916-927-1553 (fax)
1lovewellness.org
linda@onelovewellness.org
"Sacramento's largest and loving
Wellness Center"

7 Star Meds

3823 San Pablo Dam Rd.
El Sobrante, CA, 94803
(510) 758-MEDS(6337)

COLORADO

Caregivers For Life / 21+ Recreational & Medical Marijuana Center

310 Saint Paul St.
Denver, CO 80206
(720) 536-5462
Cherry Creek, Denver, CO

Karmaceuticals LLC

4 South Santa Fe Drive
Denver, CO 80223
(303)-765-2762
facebook.com/karmaceuticals
karmaceuticalsco@gmail.com
"Over 120 strains of fire"

Minturn Medicinal / Vail Valley

Minturn, CO 81645
(720) 490-0458
Free Delivery
minturnmedicinal.com

MICHIGAN

Arborside Compassion

1818 Packard Street
Ann Arbor, MI 48104
734.213.1421
arborside.net
"Compassion is our middle name."
Largest Selection of Quality
Medicine in Michigan!

Cannaisseur Collective

"A Shelf Above The Rest"
State St (call for pre-verification &
address)
Ann Arbor, MI
734-494-0772
cannaisseurcollective.com
Twitter.com/Cannaisseurlife

Lakeshore Alternatives Seed Bank

6155 Blue Star Highway
Saugatuck, MI 49453
269-857-1188
lakeshoremads@gmail.com
lakeshorealternatives.com
"West Michigan's #1 Place for
finding SEEDS"

Michigan Compassion Center

1222 Glenwood Ave.
Flint, MI 48503
970-509-0781 (Phone number)
810-265-7821 (office number)
810-265-7436 (fax number)
mccflint@gmail.com
facebook.com/
michigancompassioncenter
"Patients Come First"

Michigan Medical Marijuana

Certification Center
29877 Telegraph Road,
Suite 303 B
Southfield, MI 48034
(248) 932-6400
MMMCC.net

MSC3

227 N. Winter Street Ste 302
Adrian, MI 49221
medicinalsolutions.com
MON-FRI 10am-8pm
SAT 10am-7pm
CLOSED SUNDAYS

OM of Medicine

112 South Main Street,
3rd Floor
Ann Arbor, MI 48104
734-369-8255
omofmedicine.org
info@omofmedicine.org
"Power to the Patients!"

Pure West

Compassion Club

840 N. Black River Dr. Ste #80
Holland, MI 49424
616-466-4204
purewestclub@gmail.com
CALL TODAY & Get Doctor
Certified for \$99

MONTANA

Olympus Incendias

2591 Industry #A
Missoula, MT 59808
Phone: (406) 829-WEED
www.missoulameds.com
Customer oriented true
Compassion Center!

OREGON

Eugene Compassion Center

2055 W. 12th Ave
Eugene, OR 97402
(541) 484-6558

WASHINGTON

Conscious Care Cooperative Lake City

3215 NE 123rd St.
Seattle, WA 98125
Lakecity@cccoperative.org
https://mmjmenu.com/
dispensaries/757-conscious-care-
cooperative-lake-city
Phone: (206) 466-1206
Fax: (206) 466-1203

Purple Cross Patient Care Association

469 North 36th Street, Suite D
Seattle, WA 98103
Phone: (425) 446-1205
Fax: (206) 588-1596
purplecrosspatientcare.org
Mon-Sat, 11-9 pm Sun. 1-9 pm
Open 7 days a week!

CANADA

Note: Canadian medical clubs rarely accept US medical marijuana IDs. Prior arrangements need to be made before your visit by contacting the medical club.

CALM Toronto

P.O. Box 47023, Stn. 425
220 Yonge St.
Toronto, ON m5b 2P1
Office: (416) 367-3459
Fax: (416) 367-4679
Open 7 days a week
cannabisclub.ca

Canadian Compassion Dispensary

US patients welcome.
Phone: 647-771-9703
Toronto, ON
www.c-disp.com.

T.A.G.G.S. Dispensary

11696 224th Street
Maple Ridge, BC V2X-6A2
Phone: (604)-477-0557
Fax: (604)-477-0575
Open 7 days/week, 11am-7pm
taggsdispensary.ca
US medical patients welcome.

DISPENSARY SERVICES

Cannaline

cannaline.com
Wholesale only
301-356-9096
Stock & custom printed
glass containers, concentrate
containers & medicine bags.

T.H. SEEDS
AMSTERDAM'S FINEST
MEDICINAL GENETICS
EST. 1993
TO PROTECT GENETICS
AND SERVE MANKIND

FREE Sage'n SouR

2-Pack Feminized after every purchase of a 5-Pack, 10-Pack or a Anniversary Pack

MEDICINAL SEEDS
www.thseeds.com

Distributor:
PURE SATIVA - www.puresativa.com

ACQUISITION OF LIVE CANNABIS SEEDS IS ILLEGAL IN THE UNITED STATES
PAYABLE IN US DOLLARS FROM ANYWHERE IN THE WORLD

MITEY WAX™

"ISOLATES MITES FROM MAKING TRACKS"

AN ORIGINAL ORGANIC PRODUCT TO PREVENT AND ELIMINATE YOUR PLANTS FROM DESTRUCTIVE MITES WITHOUT THE USE OF SPRAY PRODUCTS.

- TAKE YOUR PLANTS TO A CLEANER LEVEL
- PREVENT AND ELIMINATE INFESTATIONS
- KEEP YOUR FLAVOR AND TASTE
- PROTECT UP TO 25' 4FT PLANTS WITH ONE 3 OUNCE BAR
- ECO AND USER FRIENDLY
- ALL ORGANIC
- NO GEL RESIDUE
- SINGLE APPLICATION
- COST EFFECTIVE

ORDER NOW AT:
WWW.MITEYWAX.COM OR
CALL: (951) 373-9586

We Accept:

THE OFFICIAL High Times CANNABIS COOKBOOK

GO WAY BEYOND THE BROWNIE

50+ Irresistible recipes that will get you high, including:

- Time Warp Tamales
- Pineapple Express Upside-Down Cake
- Sativa Shrimp Spring Rolls
- Pico de Gallo Nachos

INCLUDES RECIPES INSPIRED BY SNOOP DOGG, CHEECH AND CHONG, AND WILLIE NELSON!

\$18.95 • Paperback
AVAILABLE NOW AT HEADSHOP.HIGHTIMES.COM

CHRONICLE BOOKS

HIGH TIMES LEGAL DIRECTORY

ARIZONA

Jamal Allen

Allen & Associates, Lawyers
1811 S. Alma School Rd, Ste 145
Mesa, AZ 85210
Ph: 480-899-1025
Fax: 480-248-6389
goodazlawyers.com
All Stops, Arrests & Seizures

CALIFORNIA

Bob Boyd

107 W. Perkins Street, Ste #17
Ukiah, CA 95482
707-468-0500
mendocinolaw@comcast.net
mendocinolaw.com

Omar Figueroa

Law Offices of Omar Figueroa
7770 Healdsburg Ave, Ste. A
Sebastopol, CA 95472
(707) 829-0215
omar@stanfordalumni.org
omarfigueroa.com
Founder of Cannabis Law
Institute. Specializing in
cannabis cultivation and
medical marijuana cases. Free
case consultation. ¡Yo hablo
español!

Christopher M. Glew

1851 E. First Street, Ste. 840
Santa Ana, CA 92705
Fax: 714-648-0501
Phone: 714-648-0004
marijuanalawyer@yahoo.com
glewkimlaw.com

Imhoff & Associates, P.C.

Criminal Defense Attorneys
Vince Imhoff, Managing
Partner
Los Angeles, CA
800-887-0000
Info@CriminalAttorney.com
CriminalAttorney.com
Experienced, aggressive
Medical Marijuana &
Criminal Defense Attorneys
Nationwide
Free consultation

Law Offices of

John M. Kucera

1416 West Street
Redding, CA 96001
530-241-1800
jkucera@snowcrest.net
Former major grow
prosecutor.

Over 30 years of aggressive
and experienced state and
federal defense. Serving
Shasta, Siskiyou, Tehama,
Trinity and other Northern
California counties on request.
jmk-law.com

Bruce Margolin

8749 Holloway Dr.
West Hollywood, CA 90069
310-652-0991 or
800-420-LAWS
bmargolin@aol.com
1800420laws.com
margolinlawoffices.com
Marijuana and criminal
defense since 1967. Director,
L.A. NORML. Call for a free
guide to marijuana laws in all
50 states.

Eric Shevin

*NORML Legal Committee
Lifetime Member*
15260 Ventura Blvd., Ste 1050
Sherman Oaks, CA 91403
Phone: 818-784-2700
Fax: 818-784-2411
eshevin@gmail.com
shevinlaw.com
Cannabis expertise, criminal
defense and business
formation.

COLORADO

Sean T. McAllister, Esq.

McAllister Law Office, P.C.
Criminal Defense/Dispensary
Representation
Offices in Denver & Summit
County
Ph: 720-722-0048
www.mcallisterlawoffice.com

CONNECTICUT

Law Office of Aaron J. Romano, PC

45 Wintonbury Avenue, Ste 107
Bloomfield, CT 06002
Tel. 860-286-9026
attorneyaaronromano.com
Criminal Defense - MMJ
Advocacy - Expungements
15 Years of Fighting for Your
Right to be Natural

FLORIDA

James Davis

Law Office of James Davis, P.A.
300 West Adams St, Ste 550
Jacksonville, FL 32202

Office: 904.358.0420
Fax: 904.353.1359
Criminal defense focusing on
drug cases.

A. Sam Jubran, Esquire

The Law Office of A. Sam
Jubran, P.A.
Board Certified Marital &
Family Law
871 Cassat Avenue
Jacksonville, FL 32205
(904) 360-6100
www.law4jax.com

Greg M. Lauer

Board Certified Expert in
Criminal Trial Law
644 SE 5th Ave.
Ft. Lauderdale, FL 33301
(954) 559-0647
www.law-lc.com
Offices in Broward, Dade,
& WPB *Former Drug
Trafficking Prosecutor
*Free Initial Consultation

Donald A. Lykkebak

250 Park Ave South, Suite 200
Winter Park, FL 32789
Ph: 407-425-4044
Fax: 321-972-8907
don@donaldlykkebak.com
donaldlykkebak.com
"Board certified criminal trial
lawyer with over 30 years'
experience."

Porcaro Law Group

Peter J. Porcaro
1166 W. Newport Center Dr.,
Suite 309
Deerfield Beach, FL 33442
Office: (954) 422-8422
Fax: (954) 422-5455
Cell: (561) 450-9355
www.porcarolaw.com
porcarolaw@yahoo.com
Medical Marijuana, Criminal
Defense & Personal Injury.
Serving all of Florida with
focus on South Florida

Robert Shafer & Associates, P.A.

Robert Shafer
106 N. Pearl Street
Jacksonville, FL 32202-4620
Tel: 904-350-9333
Fax: 904-633-7820
shafercriminallaw.com
robert@shafercriminallaw.com
Over 30 years focusing on
drug charges.

ILLINOIS

Jeffrey B. Fawell

Fawell & Associates
500 S. Country Farm Rd,
Ste 200 Wheaton, IL 60187
630-665-9300
fawell@fawell.com
Criminal, DUI, traffic, and
immigration defense.
Imhoff & Associates, P.C.
Criminal Defense Attorneys
Vince Imhoff, Managing
Partner
Naperville, IL
800-887-0000
Info@CriminalAttorney.com
CriminalAttorney.com
Experienced, aggressive
Medical Marijuana &
Criminal Defense Attorneys
Nationwide
** Free consultation**

INDIANA

Stephen W. Dillon

Dillon Law Office
3601 N. Pennsylvania St.
Indianapolis, IN 46205
317-923-9391
steve@dillonlawindy.com
stedillonlaw.com
Chair, NORML Board
of Directors.

KANSAS

William (Billy) K. Rork

1321 SW Topeka Blvd.
Topeka, KS 66612-1816
785-235-1650
rork@rorklaw.com
rorklaw.com
Zealous and successful
drug defenses on I-70/I-35
vehicle stops.

Cal Williams

Calvin K. Williams Chtd.
280 N. Court Ave.,
P.O. Box 304
Colby, KS 67701
785-460-9777
calwilliamsesq@hotmail.com
On I-70, western Kansas.

MARYLAND

David E. Kindermann, Esq.

15 West Montgomery Ave,
Suite 300
Rockville, MD 20850
Tel: 301-762-7900 — 24/7

Fax: 301-309-0887
kindermannlaw.com
dave@kindermannlaw.com
Licensed in Maryland, D.C.
and Federal Courts incl. U.S.
Supreme Court.

MASSACHUSETTS

Norman S. Zalkind

Zalkind, Duncan & Bernstein
LLP
65A Atlantic Ave.
Boston, MA 02110
Phone: 617-742-6020
Fax: 617-742-3269
nzalkind@zalkindlaw.com

MICHIGAN

Matthew R. Abel

Cannabis Counsel PLC
2930 Jefferson Avenue East
Detroit, MI 48207
313-446-2235
attorneyabel@me.com
cannabiscounsel.com
Executive Director of
MINORML. NORML Legal
Committee Lifetime Member.
Specializing in cannabis cases
and cannabis business law.

Jason Barrix

Attorney at Law
Barrix Law Firm PC
2627 E. Beltline Ave SE,
Suite 310B
Grand Rapids, MI 49546-593
Call 24/7 Service
1-877-NO-4-Jail /
1-877-664-5245
Fax: 1-888-337-1308
barrixlaw.com
Criminal Defense Focusing
on Drug, DUI, License
and Injury Cases. "Winning
Cases Statewide since 1993"

Daniel Grow

Daniel Grow, PLLC
800 Ship Street, Suite 110
Saint Joseph, MI 49085
Office: (800) 971-8420
Fax: (269) 743-6117

Michael A. McInerney, Esq.

Michael A. McInerney, PLLC
312 E. Fulton
Grand Rapids, MI 49503
(616) 776-0200 (24 hrs)
mamgrlaw@gmail.com



FROM THE MAKERS OF THE FINEST N2O GAS

With over six decades of gas manufacturing expertise, United Brands is proud to offer you butane lighter fluid in the best form, free of contaminants. After extensive research and analysis, our technical team determined to source the purest butane from a specific gas field in the North Sea, that in turn will keep your lighters free from clogging and produce the cleanest burn.

From our single proprietary source in the North Sea



WORLD'S PUREST BUTANE



HIGH TIMES LEGAL DIRECTORY

Defending your rights!
Medical Marijuana Issues
Civil/Criminal Trial Attorney
All Michigan Courts

John Targowski

Targowski Law Office, PLLC
141 East Michigan Ave Ste 201
Kalamazoo, MI 49007
Ph: (269) 290-5606
Fax: (269) 345-1655
jtargo@icloud.com

MISSOURI

K. Louis Caskey

1102 Grand Blvd, Suite 800
Kansas City, MO 64106
Phone: 816-221-9114
Cell Phone: 816-536-1411
Fax: 816-220-0757
klouie711@aol.com
caskeyatlaw.com

Daniel Dodson

315 Marshall Street
Jefferson City, MO 65101
573-636-9200 or
800-DODSON-1
dd@danieldodson.net
danieldodson.net
Board member, NACDL;
Nationwide advice/referrals.

Dan Viets

15 N. 10th St.
Columbia, MO 65201
573-443-6866
danviets@justice.com
Former president of MO Assoc.
of Criminal Defense Lawyers,
NORML Board Chair.

MONTANA

Craig Shannon Criminal Defense Attorney

240 East Spruce Street
Missoula, MT 59802
craigks@gmail.com
Phone: 406-542-7500
Fax: 503-715-9911

NEW HAMPSHIRE

Sven Wiberg

Wiberg Law Office
2456 Lafayette Road, Suite 7
Portsmouth, NH, 03801
Phone: 603-686-5454
Fax: 603-457-0332
sven@nhcriminaldefense.com

NEW JERSEY

Frank T. Luciano, P.C.

147 Main St, Suite #5
Lodi, NJ 07644

Phone: (973) 471-0004

Fax: (973) 471-1244

cdswiz.com

Lifetime member of NORML.

Over 30 years of defending
drug prosecutions. Free book
on drug cases in New Jersey

Allan Marain

100 Bayard St.
P.O. Box 1030
New Brunswick, NJ 08903
732-828-2020

info@NJMarijuana.com

njmarijuana.com

When pleading guilty is not
an option.

Neal Wiesner

Wiesner Law Firm
34 East 23rd Street, 6th FL
New York, NY 10010
Tel: 212-732-2225
Fax: 646-678-3532
wiesnerfirm.com
nwiesner@wiesnerfirm.com

NEW MEXICO

David C. Serna

Serna Law Offices
725 Lomas Blvd. NW
Albuquerque, NM 87102
505-242-4057

sernalaw.com

Board-certified criminal-
defense specialist. NORML
lawyer since 1985.

NEW YORK

Robert S. Gershon

Law Office of Robert S. Gershon
142 Joralemon Street, Ste 5A
Brooklyn, NY 11201
718-625-3977
robertgershon.com

rg@robgershon.com

I help good people in bad
situations.

David C. Holland, Esq.

David C. Holland, P.C.
250 West 57 St., Suite 920
New York, NY 10016
212-935-4500

Licensed in NY, NJ & MD.

Neal Wiesner

Wiesner Law Firm
34 East 23rd Street, 6th FL
New York, NY 10010
Tel: 212-732-2225

Fax: 646-678-3532

wiesnerfirm.com

nwiesner@wiesnerfirm.com

OHIO

Spiros P. Cocoves

Law Offices of Spiros P.

Cocoves

610 Adams St., 2nd Flr
Toledo, OH 43604-1423
419-241-5506

Fax: 419-242-3442

scocoves@gmail.com

Federal/State Criminal
Defense, OH/MI

OKLAHOMA

M. Michael Arnett

Arnett Law Firm
3133 N.W. 63rd Street
Oklahoma City, OK 73116

Tel: (405) 767-0522

Fax: (405) 767-0529

mikearnett1@juno.com

Chad Moody

200 N Harvey Street, Ste. 110
Oklahoma City, ok 73102

Phone: 405-231-4343

Fax: 405 231-0233

thedruglawyer@

thedruglawyer.com

When a Conviction is Not an
Option

OREGON

Joshua C. Gibbs

Reynolds Defense Firm

1512 SW 18th Avenue

Portland, OR 97201

josh@KindLegalDefense.com

www.reynoldsdefensefirm.com

Ph: 541-224-8255

"We represent Kind people"

John C. Lucy IV

2121 SW Broadway, Suite 130

Portland, OR 97201

Phone: 503-227-6000

Other Phone: 919-720-2513

john@law420.com

law420.com

"Medical Marijuana and Drug
Crime Defense Throughout
Oregon"

Phil Studenberg, Attorney at Law

Southern Oregon Cannabis

Advisory, LLC

Fighting for Cannabis users

for 30 years

230 Main Street

Klamath Falls, OR 97601

Phone: 541-880-5562

Fax: 541-880-5564

www.philstudenberg.com

PENNSYLVANIA

Simon T. Grill

525 Elm Street

Reading, PA 19601

888-333-6016

STG1300@epix.net

Marijuana defense.

SOUTH CAROLINA

Robert E. Ianuario,

M.B.A., J.D.

Attorney & Counselor

419 Vardry St.

Greenville, SC 29601

Tel (864) 255-9988

Fax (866) 212-3249

sc420attorney.com

Member of Norml Legal

Committee, Member of National

College for DUI Defense

TEXAS

Blackburn & Brown L.L.P.

718 W 16th St.

Amarillo, TX 79101

Phone: 806-371- 8333

Fax: 806-350- 7716

BlackburnBrownLaw.com

ryan@ipoftexas.org

blackburn@ipoftexas.org

Greg Gladden

3017 Houston Ave.

Houston, TX 77009-6734

713-880-0333

gladden@airmail.net

Gerald Goldstein

2900 Tower Life Bldg.

San Antonio, TX 78205

210-226-1463

GGandH@aol.com

Harmony M. Schuerman

112 Hogle Street

Weatherford, TX 76086

Phone: 817-594-2161

137 Pittsburg Street, Suite J

Dallas, TX 75207

Phone: 214-212-3126

fortworthdefender.com

fortworthdefender@gmail.com

State and Federal Representation

Michael C. Lowe

Attorney At Law

700 N Pearl Street, Ste 2170

Dallas, Texas 75201

214.526.1900

Toll free: 866.351.1900

Fax:214.969.0258

dallasjustice.com

Board certified in criminal

law by the Texas board of legal

specialization

Larry Sauer

Law Offices of Larry Sauer

1004 West Ave

Austin, TX 78701

512-479-5017

austindruglawyer.com

Criminal defense.

VIRGINIA

Adam B. Crickman

Law Office of Adam B.

Crickman

3516 Plank Road, Suite 5-B

Fredericksburg, VA 22407

540-785-5500

Experienced, Aggressive

Criminal Defense.

WASHINGTON

Jeff Steinborn

P.O. Box 78361

Seattle, WA 98178

Tel: 206-622-5117

Fax:206-622-3848

Pat Stiley

Stiley & Cikutovich

1403 W. Broadway

Spokane, WA 99201

888-440-9001

fudea@earthlink.net

legaljoint.net

If you grew it, we will come.

WASHINGTON D.C.

David E. Kindermann, Esq.

15 W. Montgomery Ave,

Ste. 300

Rockville, MD 20850

Tel: 301-762-7900 — 24/7

Fax: 301-309-0887

kindermannlaw.com

dave@kindermannlaw.com

Licensed in D.C., Maryland

and Federal Courts incl. U.S.

Supreme Court.

WISCONSIN

Robert J. Dvorak

Halling & Cayo

320 E Buffalo St., Ste. 700

Milwaukee, WI 53202

414-271-3400

rjd@hallingcayo.com

Representing the accused

since 1978.

Mark D. Richards S.C.

209 8th Street

Racine, WI 53403

262-632-2200

richardslaw@ameritech.net

richardslaw1.com

Aggressive drug defense.

WORRIED ABOUT GETTING BUSTED?

DON'T GET CAUGHT WITHOUT YOUR
OWN PERSONAL BAILBONDSMAN.
**NOBODY NEEDS TO GET
OUT OF BED AT 4 A.M.**

MARIJUANA LEGAL FOR ADULTS
MEDICAL MARIJUANA LEGAL

- HABLO ESPANOL
- PRE-PAY BAILBONDS
- ALL INFORMATION IS CONFIDENTIAL

CALL T BONDS NOW!

NATIONWIDE

1-866-525-3250

440-258-6744

24 HOURS A DAY / 365 DAYS A YEAR

TBONDSBAILBONDS.COM

401 EAST ERIE AVE
LORAIN, OH 44052



@TBONDSBAILBONDSMAN



@TBOND401



@TBONDS401



SCAN HERE TO
DOWNLOAD THE APP



Pot Shots

Show us what you got!

E-mail your hi-res digital photographs to mailbag@hightimes.com.

FLOWERS OF THE MONTH

Purple Amazingness

 How ya doing? I'm a resident of the *Grasscity* forums and I've been growing for a little over three years. These plants are from a breeder in Oregon named SG1 who started Sanctuary Gardens. I've grown out a few crosses that he made and they've all turned out really nice. This one is something special though. He crossed The Purps from BC Bud Depot with Ken's Grand Daddy Purps and man, has this plant delivered! *Ironhead*



SUPERCLOSET

"Best Complete Grow Room!"

Adjustable Height Tent!
Gorilla Grow Tent is the first and only height adjustable tent. Adjust your height as your plants grow from 6'6" to 9'6" tall. The sky is the limit! Indoor Growing is limited!

No Smell!
Premium SuperRooms come standard with SuperRooms, the Gorilla Grow Tent 1680D fabric, and the closed loop system maintains your internal environment and keeps smells from escaping.

Best Air Flow!
SuperRooms come standard with Speedy Circulation Fans for the best air flow throughout your grow.

Best Grow System!
Award Winning S.T.A.S.H. SuperRooms grow your plants 25% faster and easier. Guaranteed.

Best Grow Tent!
S.T.A.S.H. AWARDED WINNER!
The Award Winning Gorilla Grow Tent is the Tallest (up to 9'6" and beyond), Thickest (1680D fabric is 3x thicker than any other grow tent), & the Strongest (all steel poles can hold up to 2000lbs!) GROW STRONG!

Best Grow Lights!
Choose either the award winning SuperRooms or the high tech full spectrum S.T.A.S.H. SuperRooms. Grow Like a Pro!

Safest Grow Room
Gorilla Grow Tents come with an industrial strength Spill Tray and a fire resistant keeping you safe on both ends. Grow with Confidence!

Fully Automated
SuperRooms are fully automated and can be left for up to 7 days of a time. Grow Easy!

Comes with EVERYTHING you need, including your Nutrients, DVD, Ph Kit, TDS Pen and More

P.O. Box 883663 San Francisco, CA 94188 www.supercloset.com ph. + 877. 476. 9787 fax. + 415. 285. 0301

420 SCIENCE ESSENTIALS

Glass
We're proud to bring you an ever-expanding selection of glass from our favorite partners. Our Grav Labs line-up is a great way to build your collection without breaking the bank.

Cleaning There's nothing better than that first rip out of a clean pipe. We've got everything you need to keep your glass sparkling clean.

Storage Store your stash in style with 420 Jars. The Official Stash Jar of the High Times Cannabis Cup.

420 SCIENCE
420Science.com

CLOSE-UP OF THE MONTH

Chemtastic

 I'm a longtime reader and medically compliant grower in Maine. I wanted to show you my Chem 91 from the Cali Connection. She was vegged for five weeks until she was a bush about 14" tall and fed the entire Advanced Nutrients line. This is from the eight-and-a-half week mark; she will be coming down in less than a week! She smells very sour and has extremely dense flowers. It's obvious the Chem is the mother to the Sour Diesel as you can see the traits from both. She has really surprised me and I now have a lot more respect for the Cali Connection: They're releasing some fire! *Eastcoastarmy*

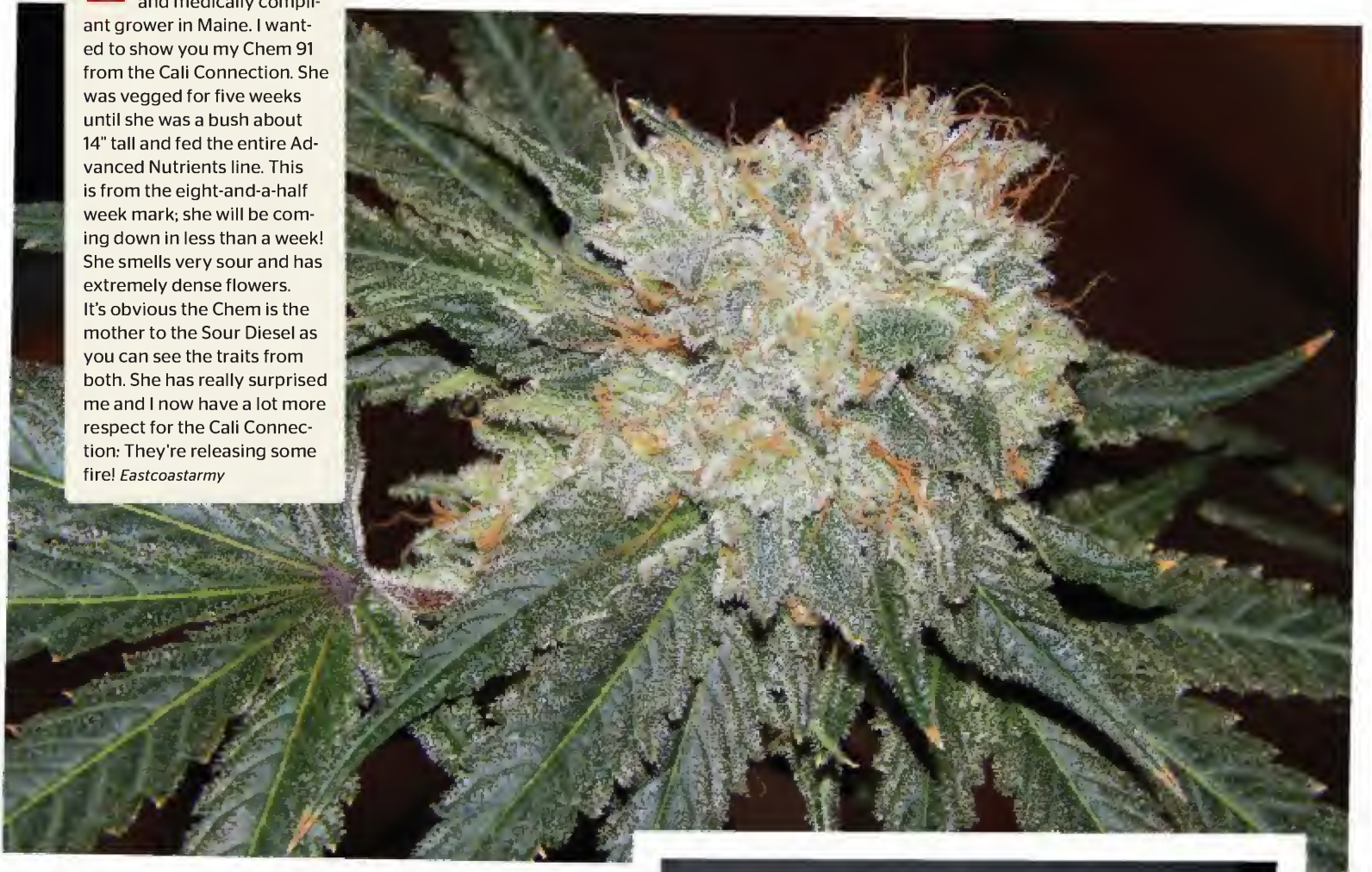

FUNGUS OF THE MONTH

Baby Boomers

 These are some pics of my last crop all grown organic in the Lone Star State. *Eli W.*



COLA OF THE MONTH

Let it Flo!

 Here's a pic of our recreational/medical garden. This is Flo x Cookie Dough. *Aaakgriffin*

BETTER WATER = BETTER YIELD



TAP MASTER™ ARTESIAN HYDROGARDENER™ REMINERALIZING REVERSE OSMOSIS (RO) WATER FILTRATION SYSTEM

- Removes 98% chlorine, chemicals, heavy metals, and hardness
- Adds 15-30 ppm cal/mag
- 150 gallons per day production; 2:1 waste ratio
- Filtration to 0.001 microns
- Modular Filters for easy service
- Non-electric pump reduces water waste up to 80%*

1.877.693.7873

www.ThePerfectWater.com

*Hydrogardener Pro™ Model



BLACK HOLES HYDRO INC.

The only dripper for
all seasons and any
grow media!

- 1/4" barb works w/ standard emitters!
- Barb available in 1/2" and 1/4" options
 - 6 observable flow holes
 - Saves time and money!
 - Reusable product

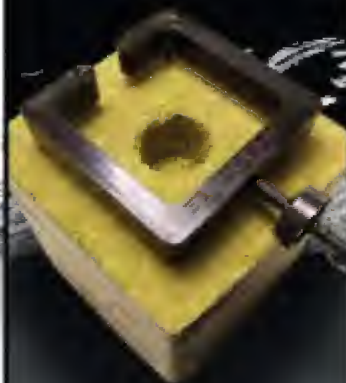

National Garden Wholesale
Sunlight Supply, Inc.

Contact Us Today For More Information:
blackholeshydro@gmail.com
www.blackholeshydro.com
Phone: (855) BHHydro (855-244-9376)



100% made in USA
100% recycled
Patent Pending

GET MORE FOR LESS. HIGHER YIELDS USING LESS NUTRIENTS!

ARE YOU READY TO
FULL ON
INCREASE YOUR YIELDS?

- ▶ Improves **PLANT HEALTH**
- ▶ **IMPROVED** water and nutrient uptake
- ▶ Better resistance to **INSECTS & DISEASE**
- ▶ Increase **SUGAR** content
- ▶ Increase **PROFITS**
- ▶ **LESS** fertilizer required
- ▶ **BETTER TASTING** crops
- ▶ Increased **SHELF LIFE** of harvested crops



FREE
Shipping

Free domestic shipping

LEARN MORE AND ORDER AT GROWSWITCH.COM

Protected retail & sales territories available

On Sale
Sept. 2nd
Don't Miss It!

November 2014

HIGH TIMES

OUR SPECIAL 40TH ANNIVERSARY ISSUE!



▶ 40 Years and Still Growing!

Happy birthday to us! *High Times* was started in 1974 by our founder and patron saint Tom Forçade, and next month we are celebrating our 40th anniversary. (And you better believe we know how to celebrate.) We'll take you on a trip backwards through history and send you on a soaring high into the future. We will tell you the wild outlaw tale of how *High Times* came to be, plus bring you some of the most beautiful cannabis pictures ever taken. Nico Escondido is going to name the greatest strains of all time, while Danny Danko is compiling a list of the most magnificent gardens *High Times* has ever seen. Plus: Marijuana microscope pics, an interview with Lester Grinspoon, the history of marijuana legalization, the confessions of a former narcotics agent and the return of Dope Rider! **DO NOT MISS THIS ONE!**

FREEBIE

MONKEYBALLZCLEANER.COM

MONKEYBALLZ

HEADY GLASS CLEANER

- ALL NATURAL
- BIODEGRADABLE
- REUSABLE
- TWICE THE SIZE OF COMPETITORS
- GETS FALLEN DABS OUT OF CLOTHES, CARPET, & LEATHER
- FIGHTS BUILD UP
- WORKS GREAT W/ EXTRACT AND CONCENTRATE RESIDUE
- WORKS IN MINUTES

WWW.HYDROHIPPIY.COM - SAN FRANCISCO - WWW.HYDROHIPPIY.COM - SAN FRANCISCO - WWW.HYDROHIPPIY.COM - SAN FRANCISCO

HYDROHIPPIY.COM

Use us and find a huge selection of products that will give you...
(Amazing Harvest Results!)

ALL PRODUCTS SHIPPED OUT OF USA

Mila's Famous
P150 P500 P3000

IT'S HARVEST TIME

2 IN 1 TRIMMER
JUST \$895
FREE SHIPPING

BubbleBee
COLLECTS CHYTRIN IN 10 MIN

DIY MAKE PRESS & INFLAT
TRIMMING TOOLS
DRY ICE SHACKERS
DRYING RACKS
PRESSES & GRINDERS

GRO-1
BEEHIVE EXTRACTORS

DROP BAGS
BUBBLE BAGS
BOLDY BAGS
GROW TENTS
AND MUCH MORE WORK

WORLD'S FASTEST TRIMMER

Bubble Bags • Bubble Box • BubbleNow
Bubble Magic Extraction Kits
Boldy Bags Made in Usa
The Funk Fighter Bags

HIGHEST QUALITY PLANT EXTRACTORS

CALL US 415.424.5352
WWW.HYDROHIPPIY.COM
ORDER ONLINE SECURE AND DISCREET

WWW.HYDROHIPPIY.COM - SAN FRANCISCO - WWW.HYDROHIPPIY.COM - SAN FRANCISCO - WWW.HYDROHIPPIY.COM - SAN FRANCISCO

VEGAMATRIX

CLEANER BIGGER BETTER



KYLEKUSHMAN™

MASTERCULTIVATOR



Exclusively distributed by

GrowLife  Greeners.com

3285 Santa Rosa Ave. Santa Rosa, CA	707.433.2333
22516 Ventura Blvd. Woodland Hills, CA	818.876.0222
40800 US Hwy 6 Unit 5 Avon, CO	970.949.1671
4800 Baseline Rd. Suite E 106 Boulder, CO	303.996.6100
301 Forest Ave. Portland, ME	207.761.2800
216 Newbury St. Unit 1 Peabody, MA	978.854.5541
13 Plaistow Rd. Plaistow, NH	603.974.2205

publicly traded under: PHOT

growlifehydroponics.com

purelifeveganix.com

**ON NOVEMBER 6TH 2012
COLORADO AND WASHINGTON
LEGALIZED MARIJUANA.**



HELP US FREE THE OTHER

**48
STATES**

**TOGETHER,
WE WILL LEGALIZE MARIJUANA.**

JOIN TODAY @ NORML.ORG

MEDI BROTHERS

LEADER IN CBD & THC EDIBLES

WHOLESALE AVAILABLE

Washington • Oregon • California

Powered by EMO TEK

Find us on weedmaps.com/medibrotherscollective

Facebook.com/medibrotherscollective

MEDIBROTHERS.COM

coming soon

Coming Soon

LIMITED EDITION MASTER YODA BAR

The Medi Brothers and Master Yoda - two cup winners collide to create a limited edition and unbelievably effective chocolate bar. Light Side or Dark Side - choose your destiny.



(Master Yoda)



(Master Yoda)



(Master Yoda)



(Medi Brothers)



(Medi Brothers)

For Custom Orders Please Call
360.258.0764



Featured Products

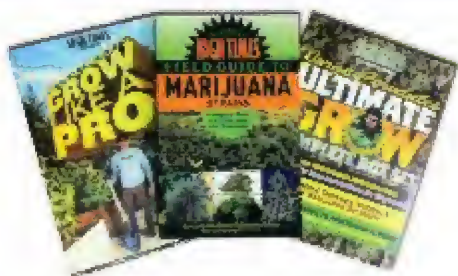

HIGH TIMES Cultivation Editors' Combo Pack
Set includes Jorge Cervantes' *Ultimate Grow Box Set*, Nico Escondido's *Grow Like a Pro*, and Danny Danko's *Field Guide to Marijuana Strains*. An \$85 value for only **\$69.99!**



HIGH TIMES Presents Nico Escondido's *Grow Like a Pro* DVD
Featuring over two hours of comprehensive cultivation coverage and bonus material, this HD-film features footage of America's top medical grow facilities, indoor and outdoor-growing and greenhouse techniques. **\$19.95**



Official HIGH TIMES Bonghitters Jersey
Show your pot pride by sporting the same shirts worn by the legendary High Times Bonghitters Softball team. Sizes: S-XXL. **\$19.95**



Ready Set Grow 1 & 2 DVD Set
The ONLY DVDs you NEED to grow great WEED! **\$34.99**



Back Issues of HIGH TIMES
Lots of issues available! HIGH TIMES: **\$5.99**; Best Of HIGH TIMES: **\$6.99**; HIGH TIMES: Medical Marijuana: **\$5.99**

Classics from master grower Jorge Cervantes

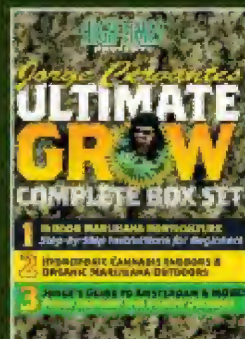

Ultimate Grow DVD Complete Box Set
Three-disc DVD box set includes *Ultimate Grow: Indoor Marijuana Horticulture*, and *Ultimate Grow 2: Hydroponic Cannabis Indoors & Organic Marijuana Outdoors*. Plus a full disc of bonus features! **\$49.95**



Marijuana Horticulture
The Fifth Edition of Jorge Cervantes' best-selling book, completely rewritten, updated and expanded! **\$29.95**



Marijuana Grow Basics
This informative guide is packed with illustrations and photos of more than 150 affordable marijuana grow setups. **\$21.95**

High Times Books



The Official HIGH TIMES Field Guide to Marijuana Strains
By Danny Danko
This cannabis compendium covers the world's top pot varieties—all meticulously researched and lovingly described in terms ranging from odors and flavors to potency levels and medicinal properties. **\$14.95**



The Official HIGH TIMES Cannabis Cookbook
by Elise McDonough
Go way beyond the brownie and master your munchies with over 50 recipes for stoner cuisine that will get you high—including recipes inspired by Cheech and Chong, Snoop Dogg and Willie Nelson. **\$19.95**

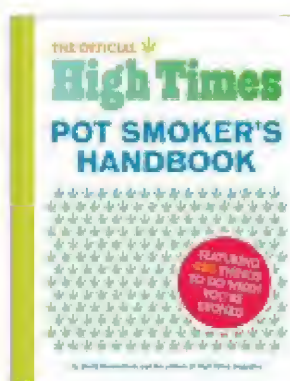

The Official HIGH TIMES Pot Smoker's Handbook
by David Bienenstock
This handbook rolls up all of our collected wisdom into one indispensable ganja guide. With a life-changing list of 420 things to do when you're stoned, this is truly the ultimate guide to green living. **\$19.95**

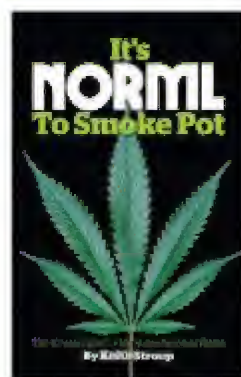

It's NORML To Smoke Pot: The 40-Year Fight For Marijuana Smokers' Rights
By Keith Stroup
The story of NORML, the oldest and most effective organization dedicated to the reform of marijuana laws, told by its founder and leader. If you believe in the principle of civil liberties, then Keith Stroup is a true American hero. **\$14.99**



The Official HIGH TIMES Pot Smoker's Activity Book
by Natasha Lewin
Smoke, play, laugh and learn all at the same time! Packed with puzzles, games, mazes, and jokes. It's what to do when you're stoned! **\$16.95**

Keep it Fresh-LY Sealed

Innovative design techniques



Truly unique designs

Trendy New DIY Hookahs

High-LY Educated

201 East Liberty Street Suite 202
Wooster, Ohio 44691
PH: 234-249-0145
FAX: 234-249-0146
www.highly-educated.com

The POT40

PASS THE DOOBIE OR DIE!



Submit your ideas by email to: pot40@hightimes.com

1

6

17

26

2

7

27

3

8

18

19

28

30

4

20

31

32

33

10

21

34

5

12

35

22

36

13

37

15

38

14

11

24

25

16

39

40

What would you like to see on the Pot 40? Write your ideas on this ballot and mail to:

HIGH TIMES
 Pot 40
 250 West 57th Street, Suite 920
 New York City, NY 10107



Free Seeds

with EVERY* order!

NEW & Bestselling Seedbanks



The following seeds

\$13.67 /each

Bay 11
REG

Bay Dream
REG

Candyland
REG

GrandDaddy Purp
REG

Ken's Kush
REG

Phantom Cookies
REG

OG Kush
REG

VISION SEEDS



The following seeds

\$6.07 /each

AK 49 Auto
FEM

Jack Herer
FEM

Lowryder Auto
FEM

Northern Lights
FEM

NY Diesel
FEM

Super Skunk Auto
FEM

White Widow
FEM

We offer both **single seeds** and **full packs of ten**, allowing you to create your perfect grow room.

Single seeds are dispatched with a portion of the original product carton. Seeds are dispatched stealthily from Great Britain and you are billed discreetly. We will replace your seeds if they do not reach you, whatever the reason!

Seeds

from

\$1.99
/Seed

DISCREET
BILLING & PACKAGING

GUARANTEED
NO BULL SHIPPING



*Subject to fair usage, see website. Prices correct at time of publication

www.thesingleseedcentre.com

ACQUISITION OF LIVE CANNABIS SEEDS IS ILLEGAL IN THE UNITED STATES
PAYABLE IN US DOLLARS FROM ANYWHERE IN THE WORLD

"In this excellent field guide, Danny's years of experience translate into easy-to-reference information on more than 125 strains, all at the flip of a finger, condensing everything you need to know into an easy-to-read, well-researched, concise package—with great photos too!" —JORGE CERVANTES, AUTHOR OF *MARIJUANA HORTICULTURE: THE INDOOR/OUTDOOR MEDICAL GROWER'S BIBLE*

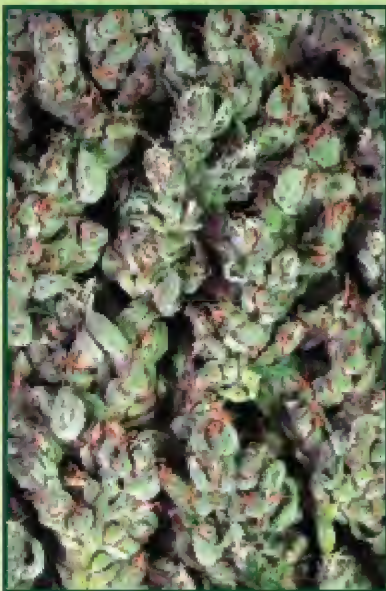

THE
OFFICIAL
HIGHTIMES
FIELD GUIDE TO
MARIJUANA
STRAINS

• Cannabis Cup® Winners
• Top 10 Strain Awards
• Over 125 pot varieties!

By Danny Danko, Senior Cultivation Editor
with a foreword by Jorge Cervantes



"If you wish to become more sophisticated about the large number of strains now available, you will be hard-pressed to find a better written and superbly photographed little compendium than this book." —DR. LESTER GRINSPOON



- Cannabis Cup® champions • "Top 10 Strain" award winners
- Over 125 pot varieties described • Cannabis buyer's guide
 - Landrace & heirloom genetics
 - Foreword by Jorge Cervantes

Available online at
HIGHTIMES.COM/HEADSHOP
or call **1-866-POT-SHOP**

Premium portable vaporizers
without the premium price



Drago Vapor is a US based distributor with wholesale opportunities available.

All designs feature:
1100 mAh battery
Stainless Steel Body

Drago
V A P O R
Just Drag and Go!

Seriously...
\$59.99

Cylinder and Globe style:
Designed for Waxes and Oils
Liquid style:
Designed for E-liquid

www.DragoVapor.com

DrugTestCheats has gone **RESPECTABLE!**
From now on, we are **DetoxClear!**

WE CARRY THE LEADING DRUG TESTING PRODUCTS AT
DISCOUNTED PRICES!

TOP SELLING DETOX PRODUCTS

- DRINKS • SHAMPOOS
- MOUTHWASHES

WORLD'S LEADING SYNTHETIC URINES

- POWDER OR PREMIXED

MOST POPULAR URINE SUBSTITUTION KITS

We Have the GoNumber 1

1-800-975-1466

WWW.DETOXCLEAR.COM

FREE SHIPPING

Save Your Strain

www.CreateSeeds.com
(877) 220-6478 ext. 102

\$5.00 off
w/ COUPON CODE NUG420

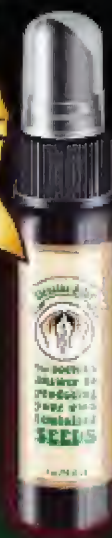

Tiresias Mist is a naturally occurring mineral mixture that allows growers to isolate a branch of a female plant and enables it to produce male characteristics (i.e. pollen sacs). Because the genetics originate from a female plant, you will only have feminized seeds...
GUARANTEED!

Available in U.S. & Canadian hydro shops
Search "Tiresias Mist" for forums, videos, & more



Reeferman Genetics

winner of 7 cups and counting!



Including the prestigious **High Life and Cannabis Cups:**

- | | |
|--|---|
| Gold x Mango - Autoflowering .. \$ 50. | Kushsicle \$100. |
| Jojo Kush \$ 50. | 🏆 Harmony \$100. |
| Mad Kush \$ 50. | Pig OC \$100. |
| Purple Eurkle x Big Bud \$ 50. | Bubba Rock \$100. |
| Reeferman Indica \$ 50. | Grand Daddy Purple \$100. |
| Chemo \$ 55. | Cherry Bomb x Skunk \$100. |
| Rockstar \$ 55. | Golden Temple Kush \$100. |
| Sour Diesel \$ 60. | Mowie Gold x Skunk \$100. |
| Double Skunk x Skunk \$ 60. | Thai x Skunk \$100. |
| Island Sweet Skunk x Skunk \$ 60. | Tuna Kush \$100. |
| Northern Lights x Skunk \$ 60. | G13 Chem Dog \$100. |
| Love Potion next gen \$ 70. | Rockstar x Diesel \$100. |
| Maple Kush \$ 70. | Afpak x Diesel \$100. |
| Moosejaw Madness \$ 70. | Pink OG \$100. |
| Blackberry Kush \$ 70. | Moosejaw Madness x Diesel \$100. |
| Kings Ransom \$ 70. | Monster Chronic x Mk \$100. |
| Zen Hash Plant \$ 75. | Bubba Kush x Diesel \$100. |
| 🏆 Love Potion (Next Gen) \$ 75. | Bubba Rockstar x OG \$100. |
| Early Purple kush \$ 75. | Alpha Dog \$100. |
| Afpak x Skunk \$ 80. | Willie Nelson x Diesel \$100. |
| Regular Afpak \$ 80. | Zen HP X Diesel \$100. |
| Bubba Rock Kush \$ 80. | O. Haze x Diesel \$100. |
| Bubble Gum Indica \$ 80. | Purple Diesel \$100. |
| Pollkat - Autoflowering \$ 80. | 🏆 Deadhead Kush winner 2013 Kush Cup .. \$100. |
| Bubba x Skunk \$ 80. | Black Willie \$ 125. |
| Reeferman Skunk \$ 80. | Pink Kush \$125. |
| Moosejaw x Skunk \$ 80. | NH21 x Early MM \$ 150. |
| G13 x Skunk | Harmony x Thai \$ 150. |
| D'ble Skunk Harmony x Skunk . \$ 80. | Malawi Gols x Thai \$ 150. |
| Original Haze x Skunk \$ 80. | 🏆 King \$ 150. |
| Purple Diesel \$ 80. | 🏆 Early Purple Kush \$ 150. |
| Sour Diesel x Skunk \$ 90. | Mullumbimby Madness x Neville's Haze 21 ... \$ 180. |
| Kodak \$100. | Neville's Haze 21 x Oaxacan \$ 180. |
| | MM x Neville's Haze 21 \$ 180. |
| | Neville's Haze 23 x SK MM \$ 180. |
| | Neville's Haze x Early MM \$ 180. |

Check out www.medicinalmss.com

for more info, and visit our online store.

email: sales@medicinalmss.com

\$11. ULTRA STEALTH WORLDWIDE SHIPPING ON ALL ORDERS

PROMO CODE: Buy 1 get the second one of equal or lesser value 50 % off

Delivery and Satisfaction are 100% Guaranteed.

ACQUISITION OF LIVE CANNABIS SEEDS IS ILLEGAL IN THE UNITED STATES

PAYABLE IN US DOLLARS FROM ANYWHERE IN THE WORLD



We accept Visa, MasterCard, and Discover card with **PHONE** in orders only **10 free seeds with orders over \$100.00!**

Please use this form

For larger orders, use a separate page listing:

- product names
- sex
- quantity
- price
- shipping rate
- order total*

*Include \$11 Shipping per order

Send along with the **BLANK Money Order** or cash for the total amount to:

PO Box 21648
Vancouver, BC
Canada V5L 3X0

Proudly Offering the World's Finest Cannabis Genetics from ONLY the very best seed breeders and original breeding stock. We are excited to present new strains from Neville, considered to be the father of the cannabis seed industry. Neville has contributed to the Monster Breeders Association strains, and now offers exotic strains of Neville's Haze crossed with Oaxacan, Mullumbimby Madness and others.



Seeds come 10 in a pack
10 Free seeds with every order over \$100!



-  Monster Breeders Association
-  Neville's New Strains

1-855-425-3437
In North America

00+1+604-357-4793
Outside North America

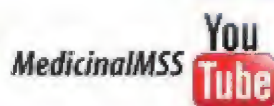
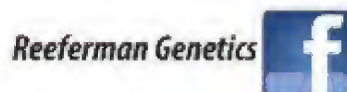
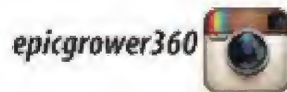

Product Name	Sex (reg/fem)	Quantity	Price
_____	_____	_____	_____
_____	_____	_____	_____
Name _____		Subtotal _____	
Address _____		S&H <input type="checkbox"/> _____	(\$11.00)
City _____	Province / State _____	Xpress Ship <input type="checkbox"/> _____	(\$30.00)
Postal / ZIP _____	Country _____	Overnight Ship <input type="checkbox"/> _____	(\$50.00)
Total			_____

ACQUISITION OF LIVE CANNABIS SEEDS IS ILLEGAL IN THE UNITED STATES | PAYABLE IN US DOLLARS FROM ANYWHERE IN THE WORLD.

866.509.4339

 **hydroponics.com**[®]



FREE \$20

Gift Card with purchase*

We'll Beat Anyone's Price...
Price match guarantee**

* with any purchase of \$20 or more, discount code: hightimes - expires 8.31.14

** If after your purchase you can find it for less within 30 days, we will gladly return the difference plus 50% to an ehydroponics.com gift card. Check out ehydroponics.com for details.